

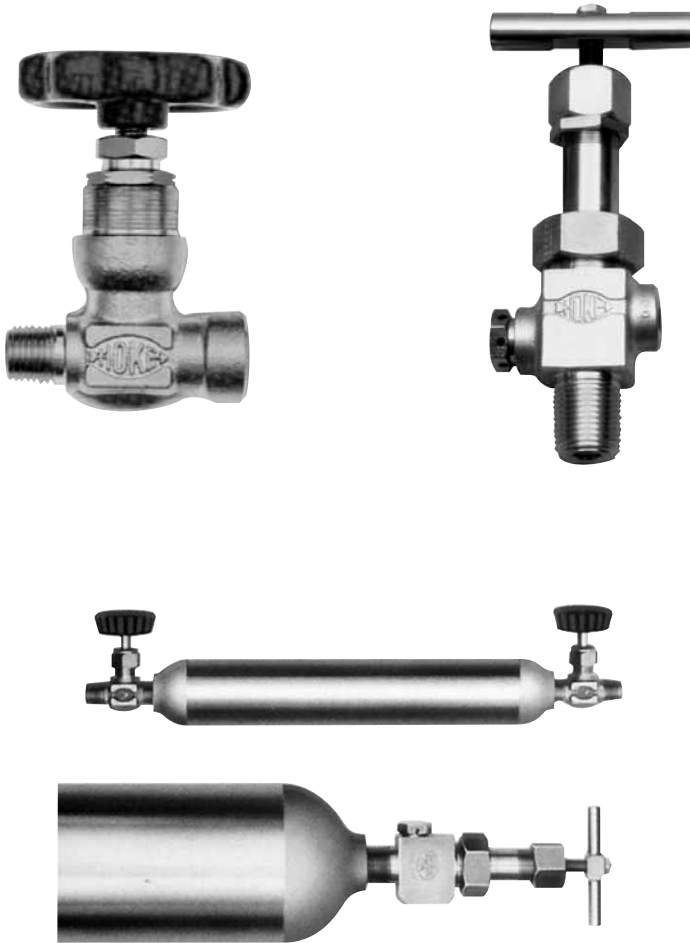

Formed Sampling Cylinders and Accessories



Index

Safety Warning	Inside Front Cover
Sampling Cylinders	2
Design, Features, Applications	
Cylinder Accessories	3
Collars, Flanges, Caps, Carrying Handles	
Safety Relief Devices	
Cylinder Valves	
1700 Series	6
2400 Series	7
3700/3800 Series	9
How to Collect Samples	11

sampling cylinders



CRANE Instrumentation & Sampling, HOKE®
PO Box 4866 • Spartanburg, SC 29305-4866
(864) 574-7966 • www.hoke.com

For Your Safety

It is solely the responsibility of the system designer and user to select products suitable for their specific application requirements and to ensure proper installation, operation, and maintenance of these products. When selecting products, the total system design must be considered to ensure safe, trouble-free performance. Material compatibility, product ratings and application details should be considered in the selection. Improper selection or use of products described herein can cause personal injury or property damage.

Contact your authorized HOKE® sales and service representative for information about additional sizes and special alloys.

SAFETY WARNING:

HOKE® products are designed for installation only by professional suitably qualified licensed system installers experienced in the applications and environments for which the products are intended. These products are intended for integration into a system. Where these products are to be used with flammable or hazardous media, precautions must be taken by the system designer and installer to ensure the safety of persons and property. Flammable or hazardous media pose risks associated with fire or explosion, as well as burning, poisoning or other injury or death to persons and/or destruction of property. The system designer and installer must provide for the capture and control of such substances from any vents in the product(s). The system installer must not permit any leakage or uncontrolled escape of hazardous or flammable substances. The system operator must be trained to follow appropriate precautions and must inspect and maintain the system and its components including the product(s) and at regular intervals in accordance with timescales recommended by the supplier to prevent unacceptable wear or failure.

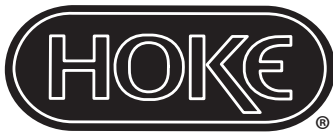

Formed Sampling Cylinders & Accessories

HOKE® Sampling Cylinders are designed and manufactured to stringent U.S. Department of Transportation (DOT) specifications as well as European Union Transportable Pressure Equipment Directive 2010/35/EU to provide long performance life and maximum safety to the user.

These cylinders are fabricated from seamless tubing or pipe with increased wall thickness in the threaded area, which prevents expansion when valves are installed. Completely formed ends maximize strength and eliminate potential leak paths. Internal sandblasting removes surface imperfections and removes foreign particles.

Single- and double-ended cylinders are available as standard in a variety of capacities from 10 milliliters to 3.5 gallons.

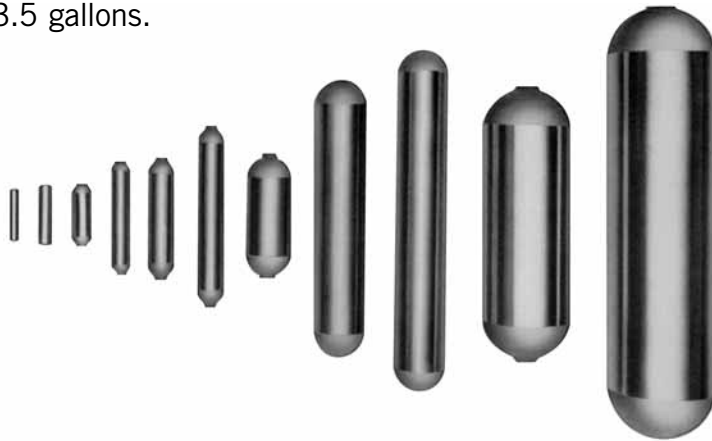

Typical Applications

- Sampling hydrocarbons in refineries and petrochemical plants
- Grab sampling for chromatographic analysis
- Snubbers in reactor feed lines
- Surge accumulators in High Pressure Gas Systems
- High Vacuum Systems as experimental chambers and molecular sieves
- Chemical reaction vessels

Features & Benefits

- Capacity ranges from 10 mL through 3.5 gallons.
- Cylinder ends come in 1/8", 1/4", 3/8" and 1/2" NPT female connections (depends on capacity).
- Standard cylinders are formed from seamless drawn 316 SS or MONEL® and Hastelloy®.
- Precision spinning operation eliminates internal pockets and provides easy flow of the sample.
- All models are internally sandblasted to remove surface imperfections and eliminate foreign particles.
- Single- and double-ended cylinders in most capacities are available as standard.
- Rugged wall thickness – extra strength around threads.
- Cylinders may be ordered with valves, relief devices, dip tubes, carrying handles, collar and flanges and end caps.
- The interior of HOKE® cylinders are available with a special FEP lining which provides excellent lubricity and very low permeability. To order, add "TL" following the cylinder part number. Restek®, Silcosteel®, and Sulfinert® surface treatments available for many sizes. Consult factory.
- Special High Tolerance NPT Thread

sampling cylinders

Formed Sampling Cylinders

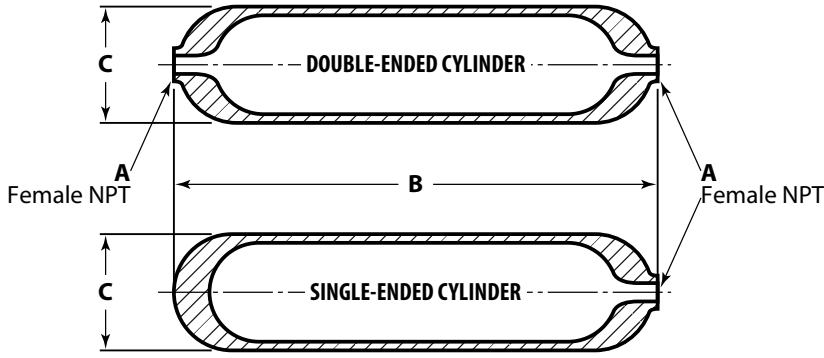

Formed Cylinders: 316 Stainless Steel only

Pressure ratings up to 5000 psig can be supplied as a special. Consult the factory for quotation of any cylinder rated above 1800 psig.

When testing to ASME specifications is required, contact HOKE® for quotation and specify maximum pressure and temperature

Other Materials

Cylinders manufactured from other materials are available. Contact HOKE® for quotation.

PTFE-lined Cylinders

The interior of HOKE® cylinders are available with a special FEP lining which provides excellent lubricity and very low permeability. To order add "TL" following the cylinder part number.

SULFINERT® COATING

Cylinders can be Sulfinert® coated, add SLF to the part number.

How to Order

To order a HOKE® Sampling Cylinder, specify the model number based on capacity required, single- or double-end connections and end connection size.

Dimensions & How to Order

PRESSURE RATING psig [bar]	INTERNAL VOLUME	A inch FEMALE NPT	ORDERING NUMBERS		DIMENSIONS inch		WEIGHT lb (kg)
			SINGLE ENDED *	DOUBLE ENDED	B LENGTH	C OUTSIDE DIAMETER	
316 Stainless Steel, 1800 psig [124 bar]							
1800 [124]	10 mL	1/8	2HSY10	2HDY10	4 [102]	0.625 [16]	0.125 [0.06]
	30 mL	1/4	4HSY30	4HDY30	4.75 [121]	1.0 [25]	0.44 [0.20]
	75 mL	1/4	—	4HDY75	4.75 [121]	1.5 [38]	0.75 [0.34]
	150 mL	1/4	—	4HDY150 □	9.25 [235]	1.5 [38]	1.4 [0.6]
	300 mL	1/4	—	4HDY300 □	9.75 [248]	2.0 [51]	2.0 [0.9]
	500 mL	1/4	—	4HDY500 □	14.5 [368]	2.0 [51]	2.9 [1.3]
	150 mL	3/8	—	6HDY150 □	9.25 [235]	1.5 [38]	1.4 [0.6]
	300 mL	3/8	—	6HDY300 □	9.75 [248]	2.0 [51]	2.0 [0.9]
	500 mL	3/8	—	6HDY500 □	14.5 [368]	2.0 [51]	2.9 [1.3]
	1000 mL	3/8	6HSY1000 □	6HDY1000 □	11.13 [283]	3.5 [89]	7.5 [3.4]
	1000 mL	1/2	8HSY1000 □	8HDY1000 □	11.0 [279]	3.5 [89]	7.25 [3.3]
	2250 mL	1/2	8HSY2250 □	8HDY2250 □	17 [432]	4.0 [102]	13.4 [6.0]
	3000 mL	1/2	8HSY3000 □	8HDY3000 □	22 [559]	4.0 [102]	16.75 [7.6]
	1 gal.	1/2	8HSY1G □	8HDY1G □	26.75 [679]	4.0 [102]	20.6 [9.3]
	2.2 gal.	1/2	—	8HDY2.2G □	24.25 [616]	6.63 [169]	57.8 [26.1]
	2.5 gal.	1/2	8HSY2.5G □	8HDY2.5G □	27.5 [699]	6.63 [169]	65.5 [29.6]
	3.5 gal.	1/2	—	8HDY3.5G □	37 [940]	6.63 [169]	94.71 [43]
HASTELLOY® 3600 PSI (248 BAR)							
	150 mL	1/4	—	4D1937150-1 □	6.5 [165]	1.9 [48]	2.6 [1.2]
	300 mL	1/4	—	4D1937300-1 □	13 [330]	1.9 [48]	4.8 [2.2]
	500 mL	1/4	—	4D1937500-1 □	20 [508]	1.9 [48]	7.2 [3.3]
	150 mL	3/8	—	6D1937150-1 □	6.5 [165]	1.9 [48]	2.6 [1.2]
	300 mL	3/8	—	6D1937300-1 □	13 [330]	1.9 [48]	4.8 [2.2]
	500 mL	3/8	—	6D1937500-1 □	20 [508]	1.9 [48]	7.2 [3.3]
	1000 mL	1/2	—	8D19371000-1 □	13.38 [340]	3.5 [89]	13 [5.9]
MONEL®							
5000 [345]	95 mL	1/4	4HSM95	4HDM95	5.25 [133]	121/32 [42]	1.5 [0.7]
	150 mL	1/4	4HSM150	4HDM150	6.5 [165]	129/32 [48]	2.4 [1.0]
	300 mL	1/4	4HSM300	4HDM300	11.75 [298]	129/32 [48]	4.0 [1.8]
	500 mL	1/4	4HSM500	4HDM500	19.5 [495]	129/32 [48]	6.13 [2.8]
3500 [241]	1000 mL	1/4	4HSM1000	4HDM1000	11.5 [292]	3.5 [89]	11.4 [5.0]

* For single-ended applications, order double-ended cylinder with plug part number 502B.

□ Can be certified to DOT

• Can be certified to TPED

Cylinders Accessories & Valves

Collars, Flanges, Caps, Carrying Handles

To enable the user to safely transport pressurized samples, HOKE® offers a variety of collar and flange assemblies, protective end caps and carrying handles. Collars can only be assembled at the HOKE® factory.

Other accessories can come completely assembled to a cylinder or may be ordered for field installation.

To order, specify the cylinder part number followed by the part number of the accessory.

Carrying Handles, Valve Protection End Caps						
ORDER BY CATALOG PART NUMBER			CYLINDER NUMBER		DIMENSIONS	
COLLAR & FLANGE ASSY. #	END CAP PART #	CARRYING HANDLE KIT PART #	HIGH PRESSURE	LOW PRESSURE	A OUTSIDE DIAMETER	B
81744-1	3107	80228-1	4HD300 6HD300 4HD500	4HD300 6HD300 4HD500	2 in 51 mm	6 5/8 in 168 mm
81744-1	3107	80228-1	6HD500	6HD500	2 in 51 mm	6 5/8 in 168 mm
80226-1	3107	80229-1	8HD1000	8HD1000	3 1/2 in 89 mm	6 5/8 in 168 mm
80227-1	3107	80230-1	8HD2250	8HD2250	4 in 102 mm	6 5/8 in 168 mm
80227-1	3107	80230-1	8HD3000	8HD3000	4 in 102 mm	6 5/8 in 168 mm
80227-1	3107	80230-1	8HD1G	8HD1G	4 in 102 mm	6 5/8 in 168 mm
81533-1	3107	80350-1	8HD2 1/2 GF	—	6 5/8 in 168 mm	6 5/8 in 168 mm
81533-1	3107	80350-1	8HD4GF	—	8 in 203 mm	6 5/8 in 168 mm
1756	3107	80228-1	4HDM150	—	1 29/32 in 48 mm	6 5/8 in 168 mm
1756	3107	80228-1	4HDM300	—	1 29/32 in 48 mm	6 5/8 in 168 mm
1756	3107	80228-1	4HDM500	—	1 29/32 in 48 mm	6 5/8 in 168 mm

All angle pattern valves shown in this catalog can be used with protective end caps. The globe pattern valves **3752M4Y2** shown on page 12 are the only globe pattern valves which can be used with protective end caps.

Dip Tubes

Dip tubes provide a vapor space of the specified volume in cylinders containing liquefied gases, allowing the liquid to expand as the temperature increases. Without adequate vapor space, a small temperature increase can cause the liquid to expand, increasing the pressure dramatically.

Refer to local regulations and other appropriate guidelines for safe cylinder filling limits for your application.

Dip tubes may be ordered in outages of 10, 20 and 30% to provide a respective filled capacity of 90, 80 or 70%. A 30% outage tube would “dip” into a cylinder to a point equivalent to the liquid level of a cylinder filled to 70% of its capacity. Dip tubes in other outages can also be ordered, contact the factory.

To ensure leak-tight performance, dip tubes must be properly welded to a fitting, valve, or relief device.

When ordering dip tubes on valves without cylinders, the cylinder model number or capacity must be identified.

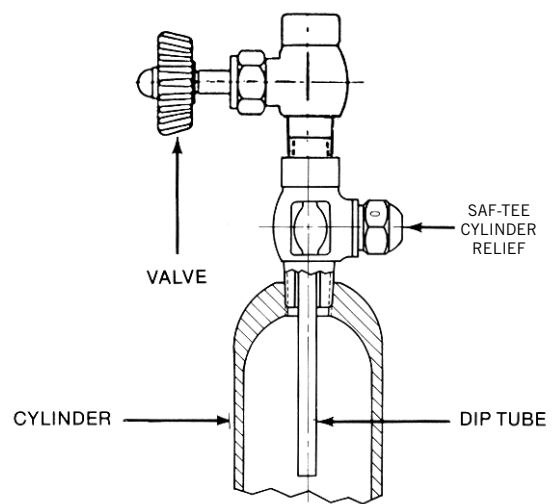
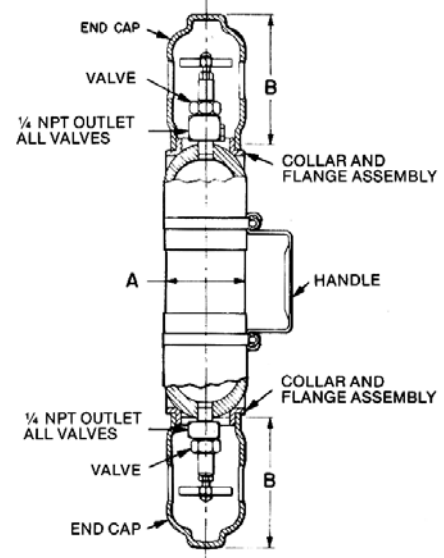

Typical Dip Tube Installation

Cylinder Accessories & Valves

Safety Relief Devices

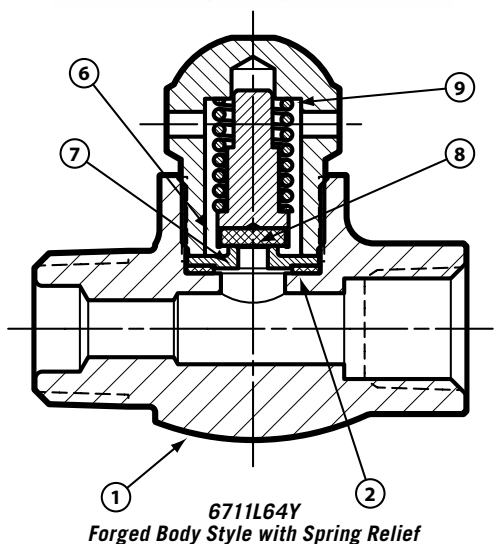
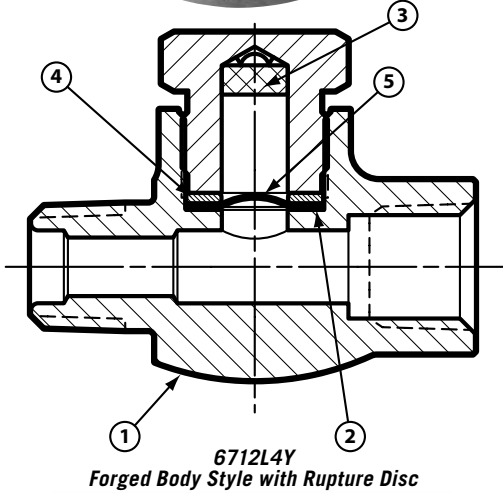
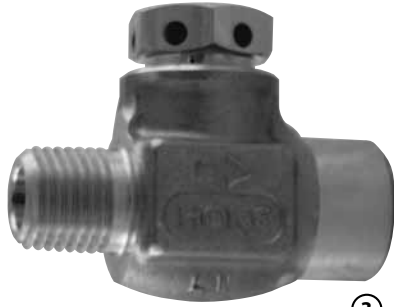

Saf-tee™ relief devices can be used with HOKE® sampling cylinders as an inexpensive safety device or as a pipe size adapter for connecting valves in the make-up of cylinder assemblies.

Two basic models are available to satisfy most pressure ranges. Spring relief models are recommended for applications where re-closure is required.

Rupture Disc models are supplied with a pre-bulged rupture disc which provides excellent resistance to a broad range of corrosive materials. A slip ring is placed between the vented hold-down plug and rupture disc to prevent damage due to torque transmission during assembly. A safety screen minimizes fragment release through the plug vents. The maximum operating system pressure should be limited to 80% of the nominal rating of the rupture disc for static operating pressure and ambient temperature. It should be limited to 70% if pressure pulsations occur or used at elevated temperature. The burst tolerance is within the ASME code guidelines.

Technical Data

OPERATING TEMPERATURE RANGE: -20° F to +250° F (-29° C to +121° C)

Materials of Construction

KEY	DESCRIPTION	RUPTURE DISC MODELS	SPRING RELIEF MODELS
1	Body	316SS	316SS
2	Gasket	PCTFE	PCTFE
3	Safety Screen	316SS	—
4	Slip Ring	316SS	—
5	Rupture Disc	INCONEL®	—
6	Seat Holder	303SS	303SS
7	Seat Ring	316SS	316SS
8	Seat	Viton®	Viton®
9	Spring	18-8SS	6712L4Y

Rupture Disc Models

INLET NPT MALE	OUTLET NPT FEMALE	ORDER BY NUMBER	ADD CODE LETTER	REPLACEMENT RUPTURE DISC KIT
1/4	1/4	6712L4Y	D - 1400-1600 psi	SP6712K1
3/8	1/4	6712L64Y	G - 1800-2000 psi	SP6712K2
			E* - 2600-3000 psi	SP6712K3
			F - 3500-4100 psi	SP6712K4**
			H - 5400-6200 psi	SP6712K5**

* Normally supplied with DOT 3E-1800 and DOT 3A-1800

** Special order only. Please contact HOKE® for details.

Rupture Disc Kits

Replacement rupture disc kits include rupture disc, safety screen, slip ring, gasket and instruction sheet (see page 5).

Spring Relief Models

INLET NPT MALE	OUTLET NPT FEMALE	ORDER BY NUMBER	ADD CODE LETTER
1/4	1/4	6711L4Y	C - 350-400 psi
3/8	1/4	6711L64Y	D* - 540-600 psi

Ordering Instructions

1. Determine whether the relief range you require is served by a spring relief or a rupture disc model.
2. Order by part number, followed by code of the desired range. For example: **No. 6712L4YD**.
3. Replacement rupture disc kits may be ordered by part number shown in the rupture disc model chart.

Cylinder Accessories & Valves

Rupture Disc Replacement Instructions

1. Disassembly:

Loosen And Remove Safety Plug (5) And Cup Screen (2) Disassemble Remaining Components. Older Models May Not Contain A Cup Screen Or Slip Ring.

2. Cleaning:

Clean All Metal Parts Thoroughly With Acetone Or Other Suitable Solvent. Clean Non-Metallic Parts With Any Detergent Type Cleaner That Meets Mil-D-16791, Type 1.

3. Lubrication:

Lubricate Safety Plug (5) Threads Lightly With Krytox 206 Or Equivalent.

4. Assembly:

Assemble Gasket (3), Then Rupture Disc (4)* With Its Convex (Bulged) Side Facing Toward The Safety Plug (5), The Slip Ring (6), And The Safety Plug (5) With Cup Screen (2). Torque Safety Plug (5) To 100-150 In-Lbs.

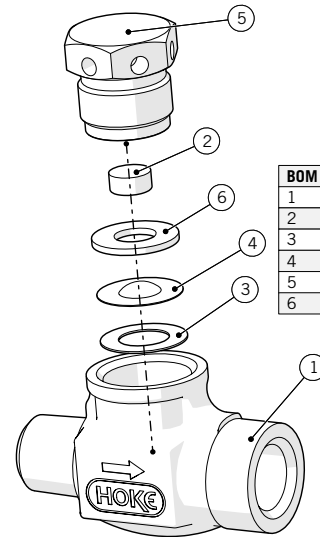

BOM ID	Description	Qty
1	Body	1
2	Cup Screen	1
3	Gasket	1
4	Rupture Disc	1
5	Safety Plug	1
6	Slip Ring	1

Note:

The Rupture Disc Assembly Should Be Tested At 70% Of Its Rated Pressure Prior To Placing It Into Service.

Caution: Do Not Exceed 70% Of Rating During Test.

* **Do Not Use Any Rupture Disc (4) That Is Bent, Nicked, Dented, Or Otherwise Damaged.**

Spring Relief, Seat, Seat Ring, and Gasket Replacement Instructions

1. Disassembly:

Loosen and remove Safety Bushing (4) and disassemble remaining components.

2. Cleaning:

Clean all metal parts thoroughly with Acetone or other suitable solvent. Clean non-metallic parts with any detergent type cleaner that meets MIL-D-16791, type 1.

3. Lubrication:

Lubricate Safety Bushing (4) threads lightly with Krytox 206 or equivalent.

4. Assembly:

Caution: Only use spring rated same as original spring range as ordered from factory. Ensure that the seat/seat holder are centered on the seat ring during assembly.

Assemble gasket (2), seat ring (6) with seat outward (as shown) seat holder with seat (3&5), spring (7), and safety bushing (4). Torque safety bushing (4) to 100-150 in-lbs.

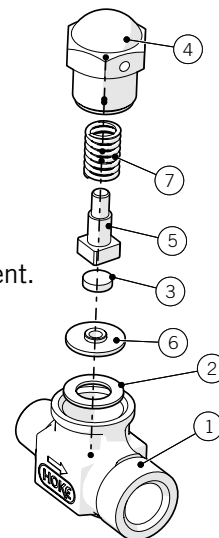

Spring Relief Spare Parts

1105-7B	Spring (350-400 PSI)
3004-4V	Seat
3004-5Y	Seat Ring
3004-6	Gasket
510-16A	Spring (540-600PSI)

BOM ID	Description	Qty
1	BODY	1
2	GASKET	1
3	SEAT	1
4	SAFETY BUSHING	1
5	SEAT HOLDER	1
6	SEAT RING	1
7	SPRING	1

Note:

The Spring Relief Valves should be tested to ensure that the required release pressure is achieved after assembly. If release pressure does not fall in range, consult factory.

Cylinder Valves

1700 Series Heavy Duty Cylinder Valves

Heavy duty compact line of 316 stainless steel and MONEL® forged body globe pattern valves features an integral bonnet suitable for ¼" and ⅜" NPT ended cylinders.

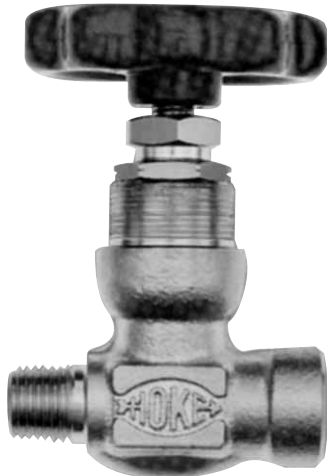

1711L4Y

Features

- Dyna-Pak packing provides a leak-tight seal with low operating torque
- Packing below stem threads prevents fluid from contacting threads
- Non-rotating hardened 17-4PH stainless steel or replaceable PCTFE stem tip prevents galling and extends valve life
- Hardened 450 stainless steel or MONEL® combination packing nut and thread gland for long stem thread cycle life
- Lock-nut secures packing nut, preventing accidental removal
- Flat wrench pads on body for easy valve installation
- Integral stem backstop for added safety

Technical Data

MAXIMUM OPERATING PRESSURE	6000 psig [414 barg]
TEMPERATURE RANGE	-65° F to +450° F [-54° C to +232° C] (metal stem tip) -20° F to +250° F [-29° C to +121° C] (PCTFE stem tip)
ORIFICE SIZE	0.187
Cv FACTOR	0.45

Materials of Constructions

DESCRIPTION		316SS Valves	MONEL® Valves
BODY		316SS	MONEL®
STEM		316SS	MONEL®
STEM TIP	SOFT	PCTFE	PCTFE
	HARD	17-4 PHSS	MONEL®
DYNA-PAK PACKING		TFE/316SS Wafers	TFE/MONEL® Wafers
HANDLE		Aluminum	Aluminum

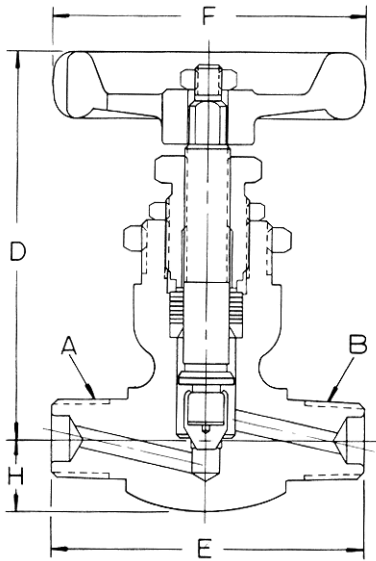

1711[]

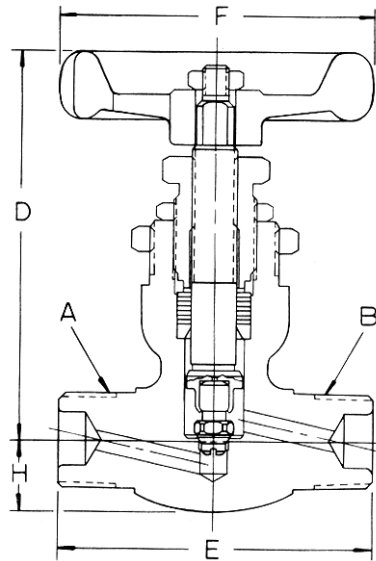

1751[]

Dimensions & How to Order 1700 Series Globe Pattern Valves

BASIC MATERIAL	STEM TIP	END CONNECTIONS		ORDERING NUMBER	DIMENSIONS inch (mm)			
		INLET A	OUTLET B		D	E	F	H
316 SS	Metal	¼ NPT Male	¼ NPT Male	1711M4Y	3 (76)	2⅜ (56)	2⅝ (54)	⅞ (12)
	Metal	¼ NPT Male	¼ NPT Female	1711L4Y	3 (76)	2⅝ (54)	2⅝ (54)	⅞ (12)
	PCTFE	⅜ NPT Male	⅜ NPT Male	1751M6Y	3 (76)	2⅜ (56)	1⅞ (48)	⅞ (12)
MONEL®	Metal	¼ NPT Male	¼ NPT Male	1711M4M	3 (76)	2⅜ (56)	2⅝ (54)	⅞ (12)
	PCTFE	¼ NPT Male	¼ NPT Male	1751M4M	3 (76)	2⅜ (56)	2⅜ (56)	⅞ (12)

Dimensions are for reference only and are subject to change

Cylinder Valves

2400 Series 1/2" Cylinder Valves



2464L84Y
with rupture disc



2466L84Y
with spring relief

2400 Series 316 stainless steel, forged body angle pattern valves, come with a union bonnet for increased safety and ease of maintenance.

Available with pressure rupture discs or spring relief devices as an integral part of the valve.

Features

- Forged body union bonnet design for ease of maintenance and maximum reliability
- Non-rotating hardened 17-4PH stainless steel tip prevents galling and extends valve life
- Dyna-Pak packing below stem threads prevents lubricant washout & contamination of process fluids
- Stem backseat provides added safety
- Available with integral rupture disc or spring relief. See page 5 for gasket, spring, seat, and rupture disc replacement instructions.

Technical Data

MAXIMUM OPERATING PRESSURE	5000 psig [345 barg]
TEMPERATURE RANGE	Metal stem tip: -40° F to +350° F (-40° C to +177° C) TFE stem tip: -20° F to +250° F (-29° C to +121° C) All burst discs & spring relief devices: -20° F to +250° F (-29° C to +121° C)
ORIFICE SIZE	0.312
Cv FACTOR	2.2

Materials of Constructions

BODY & BONNET	316SS
STEM	17-4PH
THREAD GLAND	416SS
PACKING NUT	303SS
RING GLAND	303SS



2462L84Y

Cylinder Valves

Valves with Rupture Discs					
INLET	OUTLET	ORDER BY PART NUMBER		ADD CODE LETTER	RUPTURE DISC KITS
		PTFE PACKING			
		PTFE STEM TIP	METAL STEM TIP		
				D 1400–1600 psi	SP6712K1
				G 1800–2000 psi	SP6712K2
1/2 NGT Male	1/4 NPT Female	2464L84Y	2424L84Y	E* 2600–3000 psi	SP6712K3
				F 3500–4100 psi	SP6712K4**
				H 5400–6200 psi	SP6712K5**

* Normally supplied with DOT 3E-1800 and DOT 3A-1800
 ** Special order only. Please contact HOKE® factory.

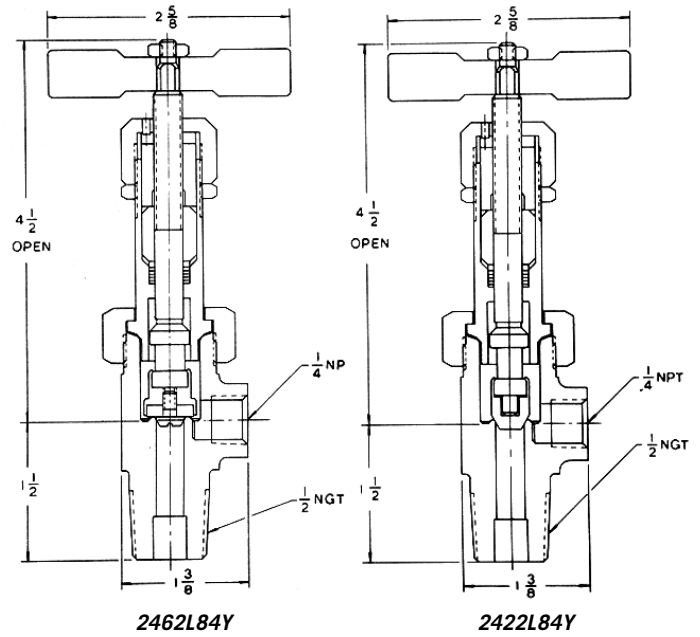

Valves without Relief Devices			
INLET	OUTLET	ORDER BY PART NUMBER	
		PTFE PACKING	
		PTFE STEM TIP	METAL STEM TIP
1/2 NGT Male	1/4 NPT Female	2462L84Y	2422L84Y

Valves with Spring Relief Devices				
INLET	OUTLET	ORDER BY PART NUMBER		ADD CODE LETTER
		PTFE PACKING		
		PTFE STEM TIP	METAL STEM TIP	
1/2 NGT Male	1/4 NPT Female	2466L84Y	2426L84Y	C 350–400 psi
				D* 540–600 psi

* Normally supplied with DOT 38-400

Ordering Instructions for Valves with Relief Devices

1. Determine whether the relief range you require is served by a spring relief or a rupture disc model.
2. Order by part number, followed by code of the desired range. For example: **No. 2424L84YD.**

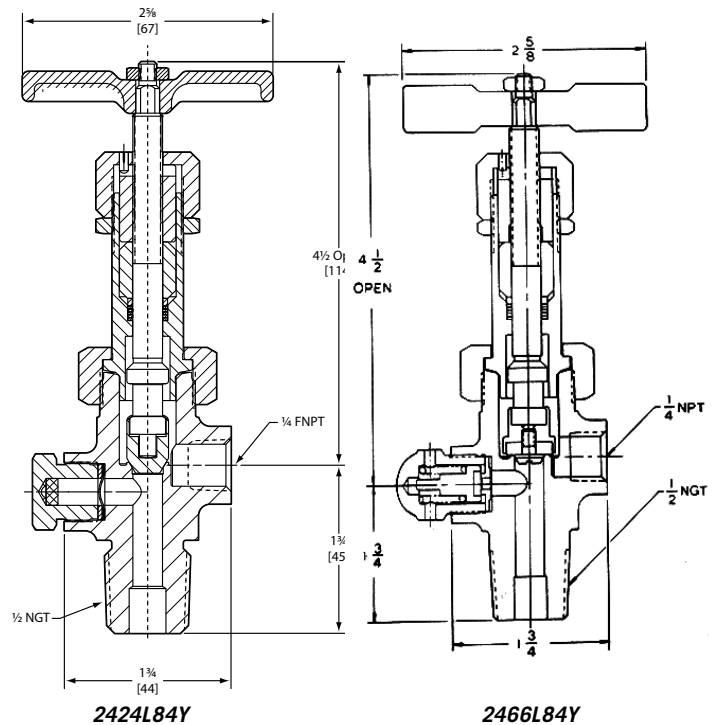

Cylinder Valves

3700 & 3800 Series Cylinder Valves



Angle 3802L4Y



Globe 3752M4Y1

The 3700 & 3800 Series forged body cylinder valves are supplied in stainless steel for cylinders with 1/8" through 3/8" NPT threads.

Features

- Compact size for restricted areas
- Dyna-Pak packing provides a leak-tight seal and low operating torque
- Integral bonnet design
- Ergonomic black ABS plastic handle
- Flat wrench pads on body for easy valve installation
- Replaceable PCTFE stem tip or integral metal stem tip
- Choice of 303 or 316 stainless steel construction
- Globe or angle flow patterns
- **3752M4Y[] Series** are designed for use with cylinder protective caps and collars on 300 and 500 mL size cylinders. Low profile and extended end allows the valve and handwheel to clear the cap and cylinder collar

Technical Data	
MAXIMUM OPERATING PRESSURE:	5000 psig (345 bar)
TEMPERATURE RANGE:	-65° F to +450° F (metal stem tip) -20° F to +250° F (PCTFE stem tip)
ORIFICE SIZES:	0.060, 0.170, 0.219
Cv FACTOR:	0.07 to 0.55

Materials of Construction		
DESCRIPTION	303SS VALVES	316SS VALVES
Body	303SS	316SS
Stem	316SS	316SS
Stem Tip (Softseat)	PCTFE	PCTFE
Dyna-Pak Packing	PTFE/316SS	PTFE/316SS
Handle*	ABS	ABS

* 303 stainless steel metal handle is provided on models **3752M4Y[]**

Handle Turns vs. Cv

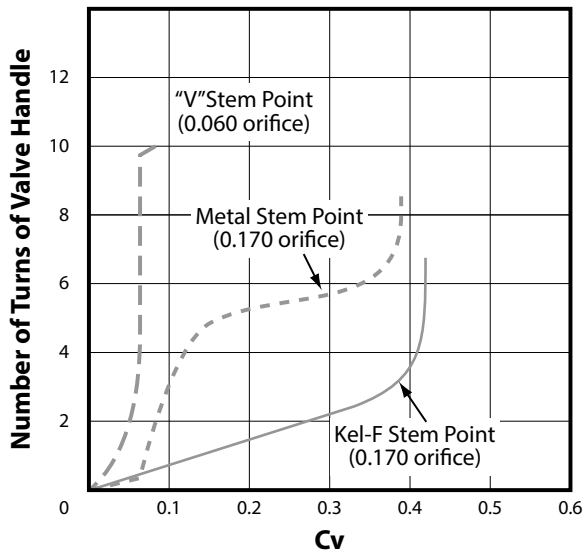

Pressure-Temperature Curve

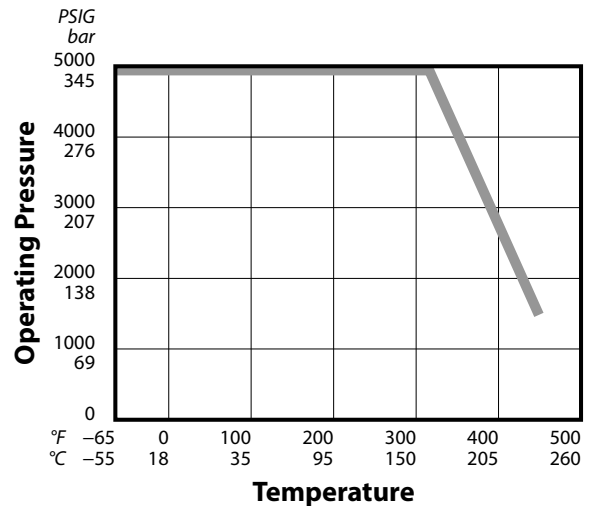

Cylinder Valves

3700 & 3800 Series Cylinder Valves

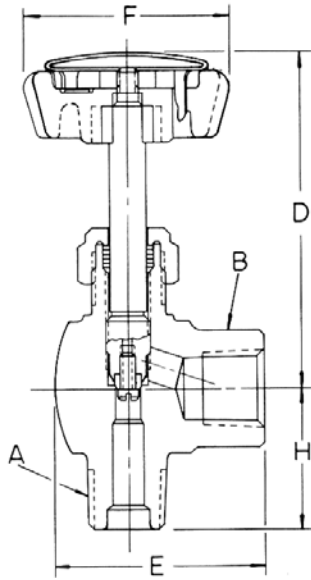

Angle 3862L64Y

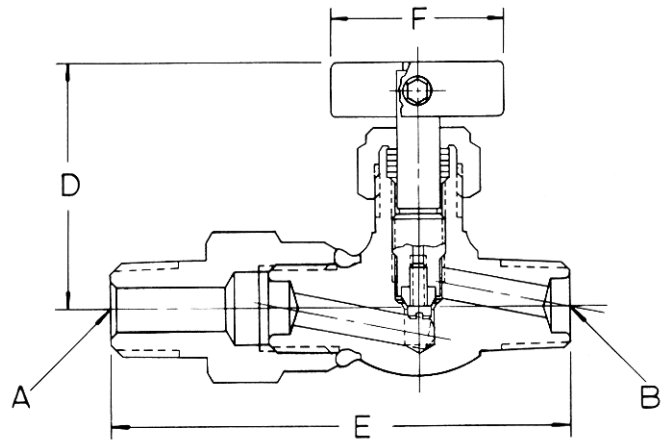

Globe 3752M4Y1

Dimensions & How to Order 3700 & 3800 Series Cylinder Valves

BASIC MATERIAL	CV	STEM TIP	END CONNECTIONS		ORDERING NUMBER	DIMENSIONS inch [mm]			
			INLET A	OUTLET B		D	E	F	H
Globe Pattern Orifice Size 0.060									
316 SS	0.07	Metal V-stem	¼ NPT Male	¼ NPT Male	3732M4Y	2 ³ / ₁₆ [56]	1 ³ / ₄ [44]	1.57 [40]	2 ⁵ / ₆₄ [10]
Globe Pattern Orifice Size 0.170									
303 SS	0.35	PCTFE	¼ NPT Male	¼ NPT Male	3752M4S	2 ¹ / ₈ [54]	2 [51]	1.57 [40]	3 ¹ / ₈ [10]
		PCTFE	¼ NPT Male	¼ NPT Female	3852L4S	2 ¹¹ / ₁₆ [68]	1 ⁷ / ₈ [48]	1.57 [40]	½ [13]
		Metal	¼ NPT Male	¼ GYROLOK®	3712H4Y	2 ¹ / ₈ [54]	1 ⁷ / ₈ [48]	1.57 [40]	3 ¹ / ₈ [10]
		PCTFE	¼ NPT Male	¼ GYROLOK®	3752H4Y	2 ¹ / ₈ [54]	1 ⁷ / ₈ [48]	1.57 [40]	3 ¹ / ₈ [10]
316 SS	0.35	Metal	¼ NPT Male	¼ NPT Male	3712M4Y	2 ¹ / ₈ [54]	2 [51]	1.57 [40]	3 ¹ / ₈ [10]
		PCTFE	¼ NPT Male	¼ NPT Male	3752M4Y	2 ¹ / ₈ [54]	2 [51]	1.57 [40]	3 ¹ / ₈ [10]
		PCTFE	¼ NPT Male	¼ NPT Male	3752M4Y2*	1 ¹³ / ₁₆ [46]	2 ³ / ₄ [70]	1 [25]	—
		PCTFE	3 ⁸ / ₁₆ NPT Male	3 ⁸ / ₁₆ NPT Male	3852M6Y	2 ¹³ / ₁₆ [71]	1 ⁷ / ₈ [48]	1.57 [40]	½ [13]
		PCTFE	½ NPT Male	¼ NPT Male	3752M4Y1*	1 ¹³ / ₁₆ [46]	3 [76]	1 [25]	—
Globe Pattern Orifice Size 0.219									
316 SS	0.55	Metal	3 ⁸ / ₁₆ NPT Male	3 ⁸ / ₁₆ NPT Male	3812M6Y	2 ²⁹ / ₃₂ [71]	2 ⁹ / ₁₆ [65]	1.57 [40]	3 ¹ / ₆₄ [12]
Angle Pattern Orifice Size 0.170									
316 SS	0.5	Metal	¼ NPT Male	¼ GYROLOK®	3722H4Y	2 ¹ / ₈ [54]	1 ¹⁹ / ₃₂ [40]	1.57 [40]	7 ¹ / ₈ [22]
		Metal	¼ NPT Male	¼ NPT Female	3802L4Y	2 ¹¹ / ₁₆ [68]	1 ²⁷ / ₆₄ [36]	1.57 [40]	3 ¹ / ₃₂ [25]
		PCTFE	¼ NPT Male	¼ NPT Female	3862L4Y	2 ¹¹ / ₁₆ [68]	1 ²⁷ / ₆₄ [36]	1.57 [40]	3 ¹ / ₃₂ [25]
		Metal	3 ⁸ / ₁₆ NPT Male	¼ NPT Female	3802L64Y	2 ¹¹ / ₁₆ [68]	1 ²⁷ / ₆₄ [36]	1.57 [40]	3 ¹ / ₃₂ [25]
		PCTFE	3 ⁸ / ₁₆ NPT Male	¼ NPT Female	3862L64Y	2 ¹¹ / ₁₆ [68]	1 ²⁷ / ₆₄ [36]	1.57 [40]	1 [25]

* Models **3752M4Y[]** are designed for use with cylinder protective caps and collars on 300 and 500 ml. cylinders. Dimensions are for reference only and are subject to change

Formed Sampling Cylinders

How to Collect Samples from Process Lines

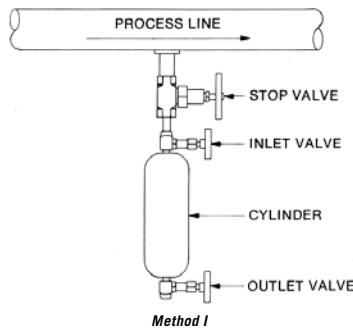

Method I

It is often difficult to obtain pure samples of process fluids for laboratory analysis. To insure accuracy and safety of your sample, DOT regulations, elimination of contaminants, cost and simplicity of operation must be considered.

Here are four methods of collecting samples which we as manufacturers and suppliers of sampling cylinders and valves have seen successfully used.

Method I: Water Displacement

1. Use a double-ended HOKE® cylinder (either the LD or HD styles depending upon pressure requirements) with sufficient capacity and equip it with suitable HOKE® valves.
2. Fill the cylinder with water so that all contaminants in the cylinder are removed by displacement.
3. Attach cylinder to process line and open process line stop valve.
4. Open both valves on sampling cylinder, the inlet valve wider than the outlet and allow the process fluid to displace the water in cylinder.
5. When cylinder is filled (this is indicated when process fluid begins flowing out cylinder outlet valve), close outlet valve and then both inlet and stop valves and remove cylinder from process line.
6. Transport cylinder to laboratory and bleed off samples as required.

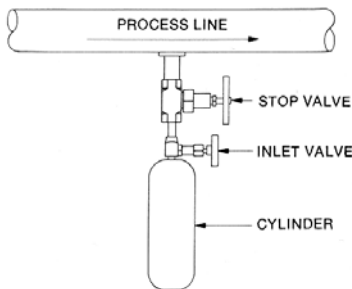

Method II

Method II: Evacuate Cylinder by Vacuum

1. Use either a double or single ended cylinder with valves, preferably packless type. Helium leak tested to insure leak tightness.
2. Evacuate the cylinder to remove contaminants.
3. Attach cylinder to process line.
4. Open inlet valve and draw off desired sample.
5. Close valve and remove cylinder from process line.
6. Draw samples from cylinder as required on mass spectrometer.

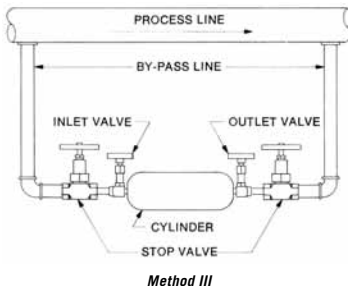

Method III

Method III: In Line By-pass of Process Line

1. Establish by-pass line or parallel line to main process line with facilities to insert sampling cylinder.
2. Insert double-ended cylinder in by-pass line.
3. Open both inlet and outlet cylinder valves wide and allow process fluid to flow through by-pass line and cylinder.
4. Permit flow to continue running until accurate sample is established.
5. Close valves and remove cylinder from process line.
6. Draw sample from cylinder when required.

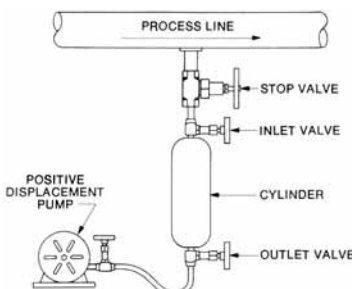

Method IV

Method IV: Positive Displacement

1. Use a double-ended cylinder equipped with suitable valves.
2. Attach one end of the cylinder to the process line and the other to a positive displacement pump which draws uniformly over a period of time.
3. Open process line and cylinder valves and begin drawing off a uniform sample over an established period of time.
4. When time period is completed, close valves and remove cylinder from process line.
5. Sample gathered is an example of fluid passed through process line over a given period.

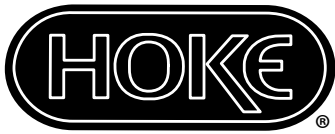

The Small Bore Instrumentation Specialists



We specialize in small bore instrumentation products up to 2" that deliver benchmark performance quality & safety; provide the broadest array of superior alloy offerings in the market; decades of proven success in a wide range of industries; a roster of "who's who" customers & projects globally; original "Best Solution" engineering & designs; and are focused on continuous improvement in all aspects of our business.

Proudly Distributed By:



CRANE INSTRUMENTATION &
SAMPLING Inc.
405 Centura Ct.
Spartanburg, SC 29305, USA
Tel: 1-864-574-7966
PO Box 4866, Spartanburg, SC
29305-4866 USA

Crane Co., and its subsidiaries cannot accept responsibility for possible errors in catalogues, brochures, other printed materials, and website information. Crane Co. reserves the right to alter its products without notice, including products already on order provided that such alteration can be made without changes being necessary in specifications already agreed. All trademarks in this material are the property of the Crane Co. or its subsidiaries. The Crane and Crane brands logotype (CENTER LINE®, COMPAC-NOZ®, CRANE®, DEPA® & ELRO®, DOPAK®, DUO-CHEK®, FLOWSEAL®, GYROLOK®, GO REGULATOR®, HOKE®, JENKINS®, KROMBACH®, NOZ-CHEK®, PACIFIC VALVES®, RESISTOFLEX®, REVO®, SAUNDERS®, STOCKHAM®, TEXAS SAMPLING®, TRIANGLE®, UNI-CHEK®, VALVES®, WTA®, and XOMOX®) are registered trademarks of Crane Co. All rights reserved.