



## R6000 Series

### Index

Safety Warning	Inside Front Cover	
R6000 Series		1
Setting Cracking Pressure		7
Seal Replacement Instructions		8
Disclaimers	Inside Back Cover	



relief valves



CRANE Instrumentation & Sampling, HOKE®  
PO Box 4866 • Spartanburg, SC 29305-4866  
(864) 574-7966 • www.hoke.com

## **For Your Safety**

---

It is solely the responsibility of the system designer and user to select products suitable for their specific application requirements and to ensure proper installation, operation, and maintenance of these products. When selecting products, the total system design must be considered to ensure safe, trouble-free performance. Material compatibility, product ratings and application details should be considered in the selection. Improper selection or use of products described herein can cause personal injury or property damage.

Contact your authorized HOKE® sales and service representative for information about additional sizes and special alloys.

## **SAFETY WARNING:**

---

HOKE® products are designed for installation only by professional suitably qualified licensed system installers experienced in the applications and environments for which the products are intended. These products are intended for integration into a system. Where these products are to be used with flammable or hazardous media, precautions must be taken by the system designer and installer to ensure the safety of persons and property. Flammable or hazardous media pose risks associated with fire or explosion, as well as burning, poisoning or other injury or death to persons and/or destruction of property. The system designer and installer must provide for the capture and control of such substances from any vents in the product(s). The system installer must not permit any leakage or uncontrolled escape of hazardous or flammable substances. The system operator must be trained to follow appropriate precautions and must inspect and maintain the system and its components including the product(s) and at regular intervals in accordance with timescales recommended by the supplier to prevent unacceptable wear or failure.



## R6000 Series®

### Right Angle Relief Valve

Available in low, medium, high and extra high pressure models, R6000 right angle relief valves provide users with high accuracy and consistency of cracking and reseal pressures. Furthermore, narrow pressure ranges (cracking pressures) for each model can be factory pre-set according to customer specifications. PED certification and CE marking are standard for all catalog models. All R6000 relief valves are offered with multiple end connections to ensure application versatility.

#### Features & Benefits

##### Low Pressure (5 – 550 psig)\*

###### *Zero friction poppets*

- Increases accuracy of cracking pressure and reseal pressure.
- Improves consistency of cracking pressure and reseal pressure.

###### *Encapsulated Seat Seal*

- Maintains small contact surface area.
- Protects seat from erosion due to flow.

Raised seal lip on poppet minimizes contact with seat, eliminating friction and preventing overstressing of the O-ring

6 pressure spring ranges improve accuracy

Caps and bodies are pre-drilled for lockwire

Multiple end connections available

- Special High Tolerance NPT Thread

##### High Pressure (150–6000 psig)

###### *3 models available:*

- Medium (150–2500 psig)—6 spring ranges improve accuracy
- High (150–5000 psig)—7 spring ranges improve accuracy
- Extra High (5000–6000 psig)—one spring

Delta stem seal design prevents friction which increases accuracy of cracking pressure and reseal pressure.

Balanced poppet design allows cracking pressure to stay the same regardless of back pressure.

Orifice sizes: 0.082", 0.094", 0.188"

Multiple end connections available.

Optional manual override handle

For European Pressure Equipment Directive (PED 2014/68/EU) applications, due to the R6000 valve's small poppet seat design, the R6000 valve is certified to be used in clean gas service ONLY (free from dust particles, contamination, etc. (gas group 1 & 2)).

\* Back pressure affects cracking pressure on low pressure version



#### Typical Applications

##### (Pure Gases Only For PED Applications)

- Beverage dispensing equipment
- Gas pilot plants
- Petrochemical test labs
- Offshore oil platform heating lines
- Pharmaceutical sterilization and packaging systems
- Alternative fuel

relief valves

# R6000 Series

## Materials of Construction

LR	
1	End
2	Body
3	Shroud ring
4	Poppet
5	Bonnet
6	Jam nut
7	Cap
8	Spring holder
9	Retaining ring
10	O-ring
11	Spring
12	Spring equalizer
13	O-ring
14	Seat o-ring
15	O-ring

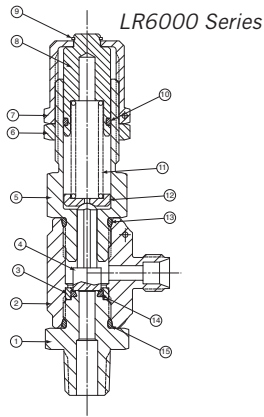

MR/HR/XR	
1	End
2	Body
3	Shroud ring
4	Poppet
5	Bonnet
6	Jam nut
7	Cap
8	Spring holder
9	Spring
10	Spring equalizer
11	O-ring
12	Delta ring
13	O-ring
14	Seat o-ring
15	O-ring

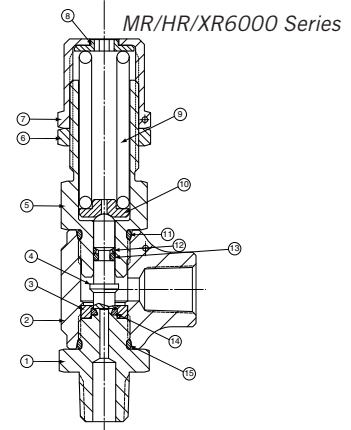

Specifications	
<b>BODY CONSTRUCTION</b>	316 stainless steel
<b>SPRING MATERIAL</b>	17-7PH CRES
<b>SEAL MATERIAL</b>	Viton® • Buna N • EPR • Kalrez® • Silicone (not available for the XR Series)
<b>CONNECTION SIZES</b>	¼"
<b>ORIFICE SIZE</b>	LR6000, MR6000: 0.188" HR6000: 0.094" XR6000: 0.082"

## Dimensions

Model No.	¼" Gyrolok® x ¼" Gyrolok®			¼" Male NPT x ¼" Gyrolok®			¼" Male NPT x ¼" Female NPT		
	A	B	C	D	E	F	G	H	J
LR	3.10" max (7.87cm)	1.34" (3.40cm)	0.97" (2.39cm)	3.10" max (7.87cm)	1.44" (3.66cm)	0.97" (2.39cm)	n/a	1.44" (3.66cm)	1.00" (2.54cm)
MR	2.94" max (7.47cm)	1.34" (3.40cm)	0.97" (2.39cm)	2.94" max (7.47cm)	1.44" (3.66cm)	0.97" (2.39cm)	2.94" max (7.47cm)	1.44" (3.66cm)	1.00" (2.54cm)
HR	2.94" max (7.47cm)	1.34" (3.40cm)	0.97" (2.39cm)	2.94" max (7.47cm)	1.44" (3.66cm)	0.97" (2.39cm)	2.94" max (7.47cm)	1.44" (3.66cm)	1.00" (2.54cm)
XR	2.94" max (7.47cm)	1.34" (3.40cm)	0.97" (2.39cm)	2.94" max (7.47cm)	1.44" (3.66cm)	0.97" (2.39cm)	n/a	1.44" (3.66cm)	1.00" (2.54cm)

\*Manual override not available for LR and XR Series

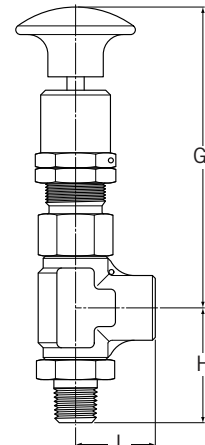
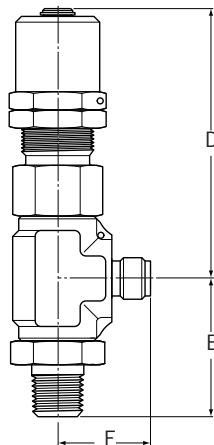
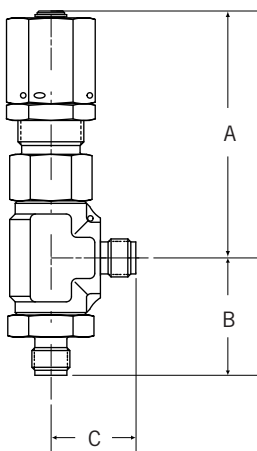

# R6000 Series

## Operating Pressures

Pressures	LR6000	MR6000	HR6000	XR6000
Cracking Pressure	5–550 psig (0–38 bar)	150–2500 psig (10–172 bar)	150–5000 psig (10–345 bar)	5000–6000 psig (345–414 bar)
Maximum Operating Pressure	5–700 psig (0–48 bar)	150–6000 psig (10–414 bar)	150–7000 psig (10–482 bar)	5000–7000 psig (345–482 bar)
Proof	1050 psig (72 bar)	9000 psig (620 bar)	9000 psig (620 bar)	9000 psig (620 bar)
Burst	Over 2800 psig (193 bar)	Over 24,000 psig (1652 bar)	Over 24,000 psig (1652 bar)	Over 24,000 psig (1652 bar)
Reseat Pressure	85% min. of CP > 10 psig 70% of CP < 10 psig	85% min. of CP	85% min. of CP	85% min. of CP

## C<sub>v</sub> Ratings

Cracking Pressure	C <sub>v</sub> LR6000 0.188"		C <sub>v</sub> MR6000 0.188"		C <sub>v</sub> HR6000 0.094"		C <sub>v</sub> XR6000 0.082"	
	Air	Water	Air	Water	Air	Water	Air	Water
	PSIG							
5	0.63	0.47	—	—	—	—	—	—
25	0.63	0.47	—	—	—	—	—	—
26	0.64	0.43	—	—	—	—	—	—
80	0.64	0.43	—	—	—	—	—	—
81	0.4	0.31	—	—	—	—	—	—
150	0.4	0.31	—	—	—	—	—	—
151	0.42	0.26	0.79	0.59	0.25	0.16	—	—
250	0.42	0.26	0.79	0.59	0.25	0.16	—	—
251	0.3	0.19	0.79	0.59	0.25	0.16	—	—
350	0.3	0.19	0.79	0.59	0.25	0.16	—	—
351	0.35	0.18	0.61	0.59	0.27	0.16	—	—
550	0.35	0.18	0.61	0.59	0.27	0.16	—	—
650	—	—	0.61	0.59	0.27	0.16	—	—
651	—	—	0.38	0.29	0.27	0.16	—	—
700	—	—	0.38	0.29	0.27	0.16	—	—
701	—	—	0.38	0.29	0.2	0.16	—	—
1001	—	—	0.37	0.20	0.2	0.14	—	—
1300	—	—	0.37	0.20	0.2	0.14	—	—
1301	—	—	0.37	0.20	0.21	0.14	—	—
1500	—	—	0.37	0.20	0.21	0.13	—	—
1501	—	—	0.28	0.14	0.21	0.13	—	—
2000	—	—	0.28	0.14	0.21	0.13	—	—
2001	—	—	0.24	0.10	0.19	0.13	—	—
2500	—	—	0.24	0.10	0.19	0.13	—	—
3000	—	—	—	—	0.19	0.13	—	—
3001	—	—	—	—	0.15	0.07	—	—
4000	—	—	—	—	0.15	0.07	—	—
5000	—	—	—	—	—	—	0.15	0.009
6000	—	—	—	—	—	—	0.12	0.006

# R6000 Series

## Pressure/Temperature Ratings

### Low Pressure

Valve No.	Seal Material	Min. Temperature °F (°C)	Pressure Range psig (bar)
LR6032	Viton®	-20° to +400° (-29° to +204°)	Up to 25 (Up to 1.7) 26–350 (1.8–24.1) 351–550 (24.2–37.9)
LR6077	Buna-N	-65° to +275° (-54° to +135°)	Up to 25 (Up to 1.7) 26–350 (1.8–24.1) 351–550 (24.2–37.9)
LR6062	Ethylene Propylene	-65° to +300° (-54° to +149°)	Up to 25 (Up to 1.7) 26–350 (1.8–24.1) 351–550 (24.2–37.9)
LR6065	Kalrez®	-40° to +550° (-40° to +288°)	Up to 25 (Up to 1.7) 26–350 (1.8–24.1) 351–550 (24.2–37.9)
LR6024	Silicone	-70° to +450° (-57° to +232°)	Up to 25 (Up to 1.7) 26–350 (1.8–24.1) 351–550 (24.2–37.9)

### Medium Pressure

Valve No.	Seal Material	Min. Temperature °F (°C)	Pressure Range psig (bar)
MR6032	Viton®	-20° to +400° <sup>1</sup> (-29° to +204°)	150–350 (10.3–24.1) <sup>1</sup> 351–2500 (24.2–172.4)
MR6077	Buna-N	-65° to +275° <sup>1</sup> (-54° to +135°)	150–350 (10.3–24.1) <sup>1</sup> 351–2500 (24.2–172.4)
MR6062	Ethylene Propylene	-65° to +300° <sup>1</sup> (-54° to +149°)	150–350 (10.3–24.1) <sup>1</sup> 351–2500 (24.2–172.4)
MR6065	Kalrez®	-40° to +550° <sup>1</sup> (-40° to +288°)	150–350 (10.3–24.1) <sup>1</sup> 351–2500 (24.2–172.4)
MR6024	Silicone	-70° to +450° (-57° to +232°)	150–350 (10.3–24.1)

### High Pressure

Valve No.	Seal Material	Min. Temperature °F (°C)	Pressure Range psig (bar)
HR6032	Viton®	-20° to +400° <sup>2</sup> (-29° to +204°)	150–300 (10.3 to 20.7) 301–5000 (20.8 to 344.8) <sup>2</sup>
HR6077	Buna-N	-65° to +275° <sup>2</sup> (-54° to +135°)	150–300 (10.3 to 20.7) 301–5000 (20.8 to 344.8) <sup>2</sup>
HR6062	Ethylene Propylene	-65° to +300° <sup>2</sup> (-54° to +149°)	150–300 (10.3 to 20.7) 301–5000 (20.8 to 344.8) <sup>2</sup>
HR6065	Kalrez®	-40° to +550° <sup>2</sup> (-40° to +288°)	150–300 (10.3 to 20.7) 301–5000 (20.8 to 344.8) <sup>2</sup>
HR6024	Silicone	-70° to +450° (-57° to +232°)	150–300 (10.3 to 20.7)

### Extra High Pressure

Valve No.	Seal Material	Min. Temperature °F (°C)	Pressure Range psig (bar)
XR6032	Viton®	-20° to +400° <sup>3</sup> (-29° to +204°)	5000–6000 (344.8–413.8) <sup>3</sup>
XR6077	Buna-N	-65° to +275° <sup>3</sup> (-54° to +135°)	5000–6000 (344.8–413.8) <sup>3</sup>
XR6062	Ethylene Propylene	-65° to +300° <sup>3</sup> (-54° to +149°)	5000–6000 (344.8–413.8) <sup>3</sup>
XR6065	Kalrez®	-40° to +550° <sup>3</sup> (-40° to +288°)	5000–6000 (344.8–413.8) <sup>3</sup>

<sup>1</sup> **Medium Pressure (MR):** In service, if an MR valve cracks above 250°F [121°C] within 1500-2000 psig [103.4-137.9 bar] OR above 200°F [93°C] and 2001 psig [138.0 bar], the valve shall be removed from service, the O-rings shall be replaced, and the pressure set point shall be reset by qualified individuals.

<sup>2</sup> **High Pressure (HR):** In service, if an HR valve cracks above 200°F [93°C] within 1500-4000 psig [103.4-275.8 bar] OR above 150°F [65°C] and 4001 psig [275.8 bar], the valve shall be removed from service, the O-rings shall be replaced, and the pressure set point shall be reset by qualified individuals.

<sup>3</sup> **Extra High Pressure (XR):** In service, if an XR valve cracks above 150°F [65°C], the valve shall be removed from service, the O-rings shall be replaced, and the pressure set point shall be reset by qualified individuals.

# R6000 Series

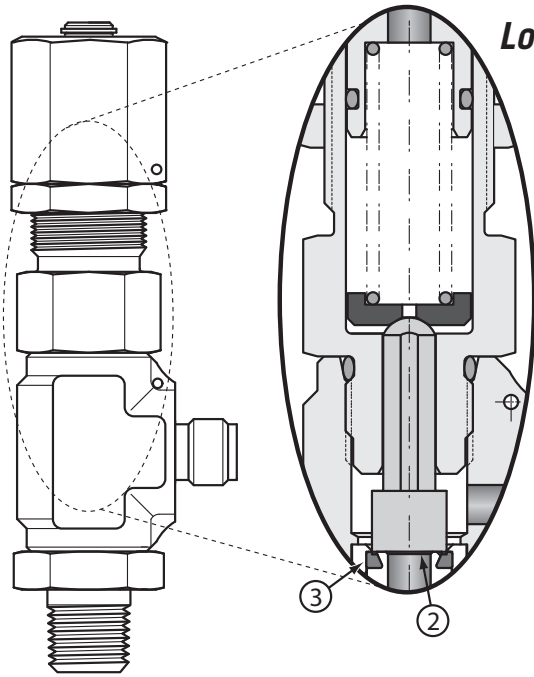

**Low Pressure** 5–550 psig (0-38 bar)

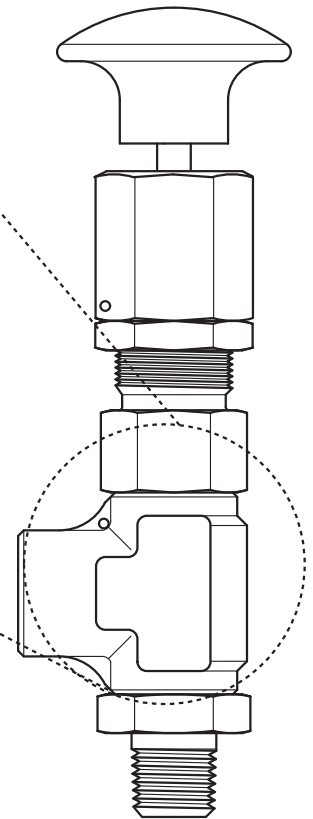
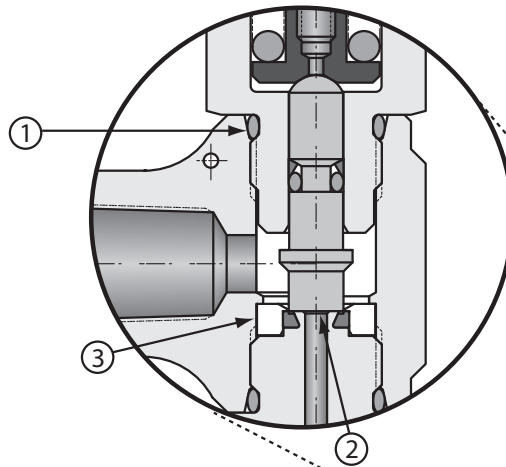

**Medium Pressure** 150-2500 psig  
(10-172 bar)

**High Pressure** 150-5000 psig  
(10-345 bar)

**Extra High Pressure** 5000-6000 psig  
(345-414 bar)

## Features

① O-ring & Delta backup ring

② Raised seal lip

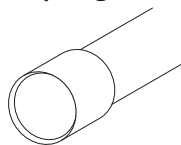

③ Fully encapsulated seat seal

# R6000 Series

## Crack Pressure Range

Select appropriate spring code

LR6000 Low Pressure		MR6000 Medium Pressure		HR6000 High Pressure		XR6000 Extra High Pressure	
Spring Code	Range in PSIG (BAR)	Spring Code	Range in PSIG (BAR)	Spring Code	Range in PSIG (BAR)	Spring Code	Range in PSIG (BAR)
A	5–25 (0–2)	B	150–350 (10–24)	A	150–300 (10–21)	A	5000–6000 (345–414)
B	26–80 (2–6)	C	351–650 (24–45)	B	301–700 (21–48)		
C	81–150 (6–10)	D	651–1000 (45–69)	C	701–1300 (48–90)		
D	151–250 (10–17)	E	1001–1500 (69–103)	D	1301–2000 (90–138)		
E	251–350 (17–24)	F	1501–2000 (104–138)	E	2001–3000 (138–207)		
F	351–550 (24–38)	G	2001–2500 (138–172)	F	3001–4000 (207–276)		
				G	4001–5000 (276–345)		

## How to Order

**LR60 24 – 2MP – A H M – \* \* \* \***

**BASIC MODEL NUMBER**

- LR60** Low pressure  
5–550 psig (0–38 bar)
- MR60** Medium pressure  
150–2500 psig (10–172 bar)
- HR60** High pressure  
150–5000 psig (10–276 bar)
- XR60** Extra high pressure  
5000–6000 psig (345–414 bar)

**SEAL MATERIAL**

- 24** Silicone\*
- 32** Viton®
- 62** Ethylene propylene
- 65** Kalrez®
- 77** Buna-N

**MANUAL OVERRIDE**  
(optional, not available for LR or XR series)  
MR series only available up to 350 psig (24 bar).  
HR series only available up to 700 psig (48 bar).

**HOKE**

**SPRING CODE**  
See Crack Pressure table above

**PORT SIZE**

	Inlet	Outlet
<b>2MP</b>	¼" male NPT	¼" female NPT
<b>2M4G</b>	¼" male NPT	¼" GYROLOK®
<b>4G</b>	¼" GYROLOK®	¼" GYROLOK®
<b>2RT</b>	¼" BSPT male	¼" BSPT female
<b>6Z</b>	6mm GYROLOK®	6mm GYROLOK®
<b>8Z</b>	8mm GYROLOK®	8mm GYROLOK®
<b>12Z</b>	12mm GYROLOK®	12mm GYROLOK®

R6000 valves are PED certified

- \* Silicone seals are not available for XR series.
- \* Silicone seals for MR series only available up to 350 psig (spring code B)
- \* Silicone seals for HR series only available up to 300 psig (spring code A)

\*\*\*\*Customer can request a specific cracking pressure when ordering. To specify, add the cracking pressure as -PSIG (not BAR) after the M for Manual Override (if no override, add value after "H"). Otherwise, the factory sets the valve at the nominal midpoint of the cracking pressure range selected. Valves with specific cracking pressure include standard factory installed lockwire. For example, **LR6024-2MP-AH-M-25**.

Due to factors outside of the manufacturer's control, the initial crack pressure of the installed valve may be higher than the stated set pressure. This also applies if the valve has not been actuated for a period of time.

## R6000 Service Kits

**LR Kit** includes: end seat-to-body O-ring, bonnet-to-body O-ring, and bonnet seal O-ring.

**MR/HR/XR Kit** includes: end seat-to-body O-ring, bonnet-to-body O-ring, seat O-ring, and Delta seal. Replacement of Delta seal requires use of installation tool and resizing tool. Consult factory for details.

To Order, add **K** to front of valve part number (example: **KLR6024-2MP-AH**).

### Delta Back-Up Ring Replacement Tool Sets

59-1364-IT	LR/MR Install Tool
59-1364-RT	LR/MR Resize Tool
59-1365-IT	HR Install Tool
59-1365-RT	HR Resize Tool
59-1366-IT	XR Install Tool
59-1366-IT	XR Resize Tool

# R6000 Series

## INSTRUCTIONS FOR SETTING CRACKING PRESSURE

**CAUTION: A LEAK DETECTION METHOD SHALL BE ESTABLISHED TO DETECT ANY VISIBLE AIR OR N2 ACROSS THE VALVE SEAT. THIS LEAKAGE DETECTION METHOD SHOULD ENSURE SAFETY DURING TESTING.**

1. Valves not custom preset by the factory do not have lock wire securing the cap. These valves are nominally set in the middle of the basic crack pressure range.
2. Loosen the jam nut and lower to provide sufficient clearance to allow adjustment of the cap.
3. On all models except LR6000, insert a  $\frac{3}{16}$ " Allen wrench in the thrust washer hex hole on top of the valve to prevent the thrust washer from turning in the next step.
4. Apply pressurized air or N2 at the desired cracking pressure to the valve inlet.
5. Using a  $\frac{7}{8}$ " wrench, slowly turn the cap until the valve just starts to leak one bubble per second. Clockwise rotation increases the cracking pressure, counterclockwise decreases the cracking pressure. It may be necessary to temporarily set the cracking pressure higher than that desired in order to adjust until one bubble per second leakage is achieved.
6. Recheck the setting by reducing the inlet pressure to zero, then re-pressurize to the desired cracking pressure. Repeat step 5 if necessary.
7. After the desired cracking pressure is set, reduce inlet pressure to zero. Tighten the jam nut against the cap with 145-155 in-lbs torque. Do not turn the cap when tightening the jam nut.
8. Test for zero outlet leakage for 30 seconds with 95% of cracking pressure applied to inlet.
9. For European Pressure Equipment Directive (2014/68/EU) applications, due to the R6000 valve's small poppet seat design, the R6000 valve is certified to be used in clean gas service ONLY (free from dust particles, contamination, and etc. (gas group 1 & 2)).

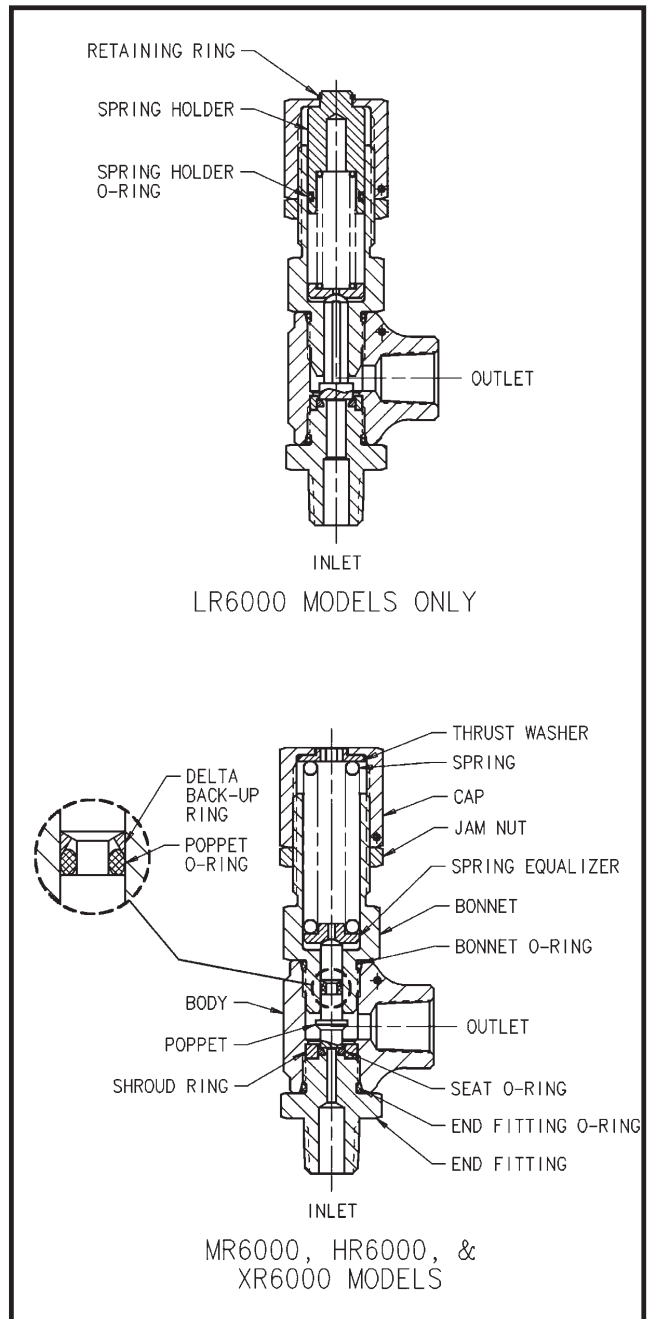

# R6000 Series

## INSTRUCTIONS FOR SEAL REPLACEMENT

**WARNING: MAKE SURE THE SYSTEM IS NOT PRESSURIZED WHEN WORKING ON ANY COMPONENT, VALVE OR FITTING. NORMAL SAFETY PRACTICES REGARDING DEACTIVATED SYSTEMS SHOULD BE FOLLOWED.**

1. Loosen the jam nut and lower to provide sufficient clearance to allow adjustment of the cap.
2. Unscrew the cap keeping the thrust washer (spring holder on LR6000 models) inside with the cap. For LR6000 models, temporarily remove the retaining ring and discard spring holder o-ring.
3. Remove the spring and spring equalizer from the bonnet.
4. Unscrew the bonnet from the body.
5. Carefully remove the poppet from the bonnet. Discard bonnet o-ring.
6. For all models except LR6000: Inspect the Delta back-up ring and o-ring for damage or wear. Replace if necessary—see step 12.
7. Unscrew the end fitting from the body. Discard the end fitting o-ring.
8. Gently pry off the shroud ring to expose the seat o-ring. Discard the seat o-ring.

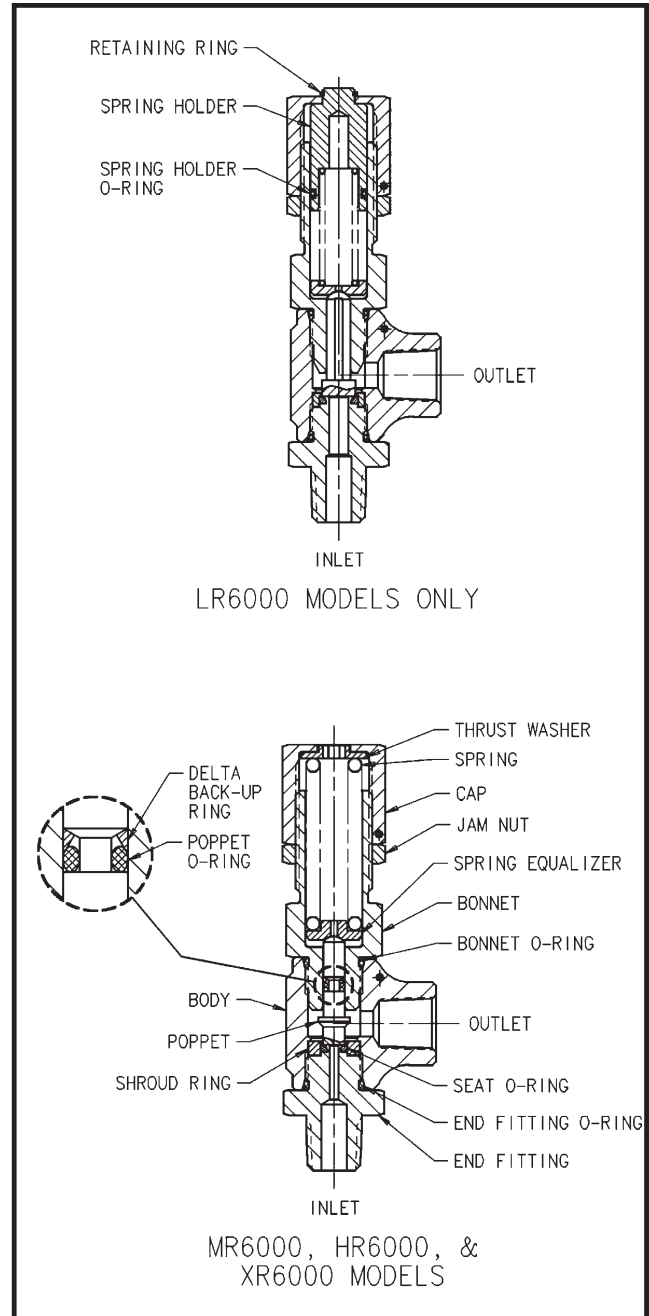

# R6000 Series

Prior to re-assembling, lubricate all thread and o-rings sparingly with Krytox 206 or equivalent.

**CAUTION: MAKE SURE THE END FITTING AND POPPET SEALING SURFACES ARE NOT DAMAGED DURING REASSEMBLING. TAKE CARE NOT TO NICK OR PINCH O-RINGS DURING RE-ASSEMBLING.**

9. Place new end fitting and seat o-rings onto the end fitting.
10. Press the shroud ring over the seat o-ring until it bottoms out.
11. Screw assembled end fitting into the body and torque to 160-170 in-lbs. The end fitting goes in the hole opposite the  $\frac{1}{16}$ " diameter lockwire hole.
12. If the Delta back-up ring and the poppet o-ring are to be replaced, re-install as follows (Delta back-up ring tools are available from your distributor.):
13. Lubricate the poppet o-ring and the Delta back-up ring sparingly
14. Slide the poppet o-ring onto the poppet and into the groove.
15. With the lube applied to the Delta backup ring, place with long tapered leg first on the tapered end of bullet tool. Slowly and evenly push until the backup ring has been pushed beyond the cone.
16. Place the open end of the bullet tool over the poppet on the round nose end. Push the Delta back-up ring off the bullet tool and into the poppet o-ring groove.
17. Push the poppet assembly into the sizing tool with the o-ring side first. Push back and forth three to four times before removing to resize the Delta back-up ring.
18. Insert the poppet into the bonnet. Screw the bonnet into the body and torque to 160-170 in-lbs.
19. With the spring vertical, place spring equalizer button-side down on top of spring and slide into the bonnet, spring equalizer first. The indent on the spring equalizer should engage the rounded exposed end of the poppet.
20. For LR6000 models: Install the spring holder o-ring onto the spring holder. Reinstall the spring holder in cap with retainer ring.
21. With the thrust washer (or spring holder for LR6000 models) inside the cap, engage cap onto bonnet 2 or 3 turns.
22. Using a  $\frac{3}{16}$  Allen wrench keep the thrust washer from rotating while screwing the cap down half the thread length (approximately 4 more turns). For LR6000 models, just screw cap down half the thread length (approximately 4 more turns)
23. Re-establish the cracking pressure.

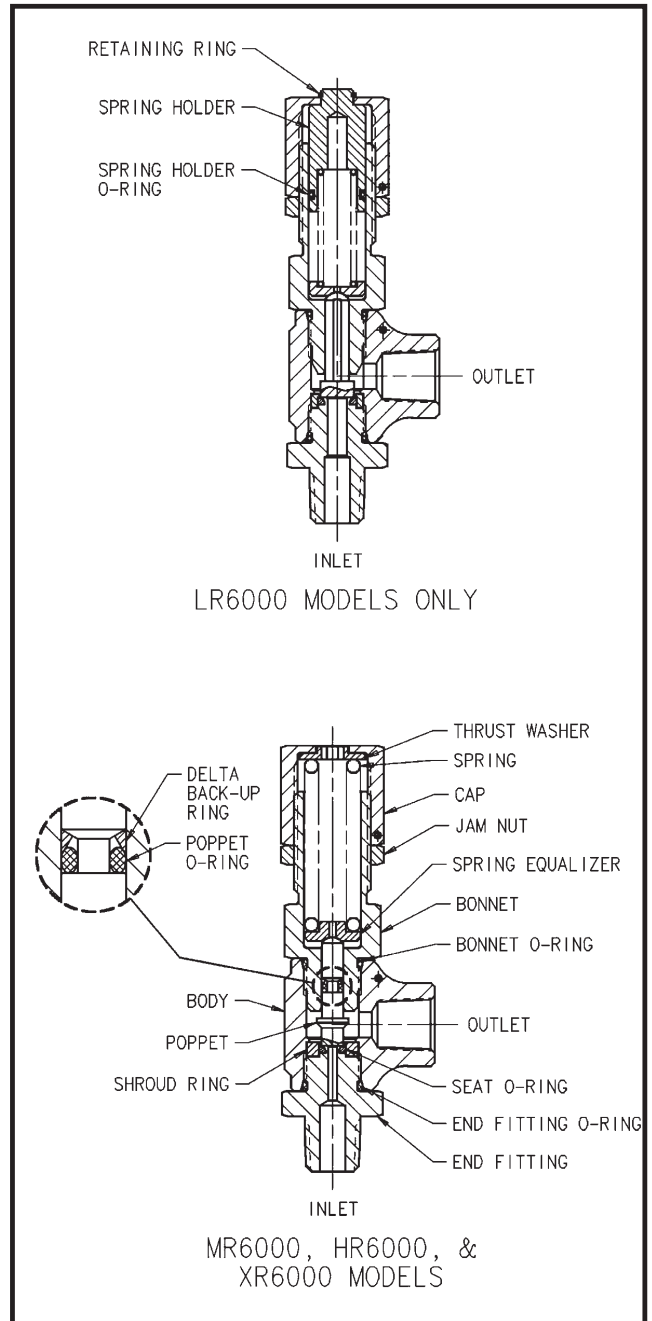











---

## The Small Bore Instrumentation Specialists

---



We specialize in small bore instrumentation products up to 2" that deliver benchmark performance quality & safety; provide the broadest array of superior alloy offerings in the market; decades of proven success in a wide range of industries; a roster of "who's who" customers & projects globally; original "Best Solution" engineering & designs; and are focused on continuous improvement in all aspects of our business.

### Proudly Distributed By:

---



CRANE INSTRUMENTATION &  
SAMPLING Inc.  
405 Centura Ct.  
Spartanburg, SC 29305, USA  
Tel: 1-864-574-7966  
PO Box 4866, Spartanburg, SC  
29305-4866 USA

Crane Co., and its subsidiaries cannot accept responsibility for possible errors in catalogues, brochures, other printed materials, and website information. Crane Co. reserves the right to alter its products without notice, including products already on order provided that such alteration can be made without changes being necessary in specifications already agreed. All trademarks in this material are the property of the Crane Co. or its subsidiaries. The Crane and Crane brands logotype (CENTER LINE®, COMPAC-NOZ®, CRANE®, DEPA® & ELRO®, DOPAK®, DUO-CHEK®, FLOWSEAL®, GYROLOK®, GO REGULATOR®, HOKE®, JENKINS®, KROMBACH®, NOZ-CHEK®, PACIFIC VALVES®, RESISTOFLEX®, REVO®, SAUNDERS®, STOCKHAM®, TEXAS SAMPLING®, TRIANGLE®, UNI-CHEK®, VALVES®, WTA®, and XOMOX®) are registered trademarks of Crane Co. All rights reserved.