



Fluid Control Components

Index

Safety Warning	Inside Front Cover
Check valves	
CVH Series	1
Check valves	
XVH Series	5
Excess flow valves	
6100/6200 Series	10
Check valves	
R6000 Series	13
Adjustable relief valves	
6600 Series	19
Bleed valves	
6300 Series	22
Toggle valves	
6800 Series	24
Disclaimers	Inside Back Cover



fluid control



CRANE Instrumentation & Sampling, HOKE®
PO Box 4866 • Spartanburg, SC 29305-4866
(864) 574-7966 • www.hoke.com

For Your Safety

It is solely the responsibility of the system designer and user to select products suitable for their specific application requirements and to ensure proper installation, operation, and maintenance of these products. When selecting products, the total system design must be considered to ensure safe, trouble-free performance. Material compatibility, product ratings and application details should be considered in the selection. Improper selection or use of products described herein can cause personal injury or property damage.

Contact your authorized HOKE® sales and service representative for information about additional sizes and special alloys.

SAFETY WARNING:

HOKE® products are designed for installation only by professional suitably qualified licensed system installers experienced in the applications and environments for which the products are intended. These products are intended for integration into a system. Where these products are to be used with flammable or hazardous media, precautions must be taken by the system designer and installer to ensure the safety of persons and property. Flammable or hazardous media pose risks associated with fire or explosion, as well as burning, poisoning or other injury or death to persons and/or destruction of property. The system designer and installer must provide for the capture and control of such substances from any vents in the product(s). The system installer must not permit any leakage or uncontrolled escape of hazardous or flammable substances. The system operator must be trained to follow appropriate precautions and must inspect and maintain the system and its components including the product(s) and at regular intervals in accordance with timescales recommended by the supplier to prevent unacceptable wear or failure.



CVH Series

Check Valves



The CVH Series Check Valves are engineered for a competitive price with no compromise of quality and performance to meet the growing requirements of instrumentation valves. The function of this valve series is to maintain system integrity by preventing back flow of a wide variety of fluids over a broad range of pressures.

Features & Specifications

- Rapid response
- Resilient o-ring seat provides cushioned, noise-free closing and zero leakage
- Floating o-ring design: o-ring is continually cleaned so contaminants do not prevent sealing
- Various materials of construction can be used with any liquid or gas service
- Various end connections can be assembled in any system or application
- Spring-loaded poppet can be mounted in any orientation
- Full flow with minimal restriction for maximum Cv rates
- Virtually maintenance free for maximum dependability
- Pressures up to 6000 psig (414 bar)
- Cracking pressure range is 0.5 to 20 psig (0 to 1 bar) $\pm 10\%$
- Flow up to 7.4 Cv maximum
- Greater than 100,000 life cycles
- Special High Tolerance NPT Thread

Technical Data

Body Material*	316 stainless steel, MONEL® R-405, HASTELLOY® C-276
Operating Pressure Range	0 to 6000 psig (414 bar)
Temperature Range**	-65° F to +550° F (-54° C to +288° C)
Cv factors	0.32 to 7.4
Cracking Pressure Range	0.5 to 20 psig (0.035 to 1.379 bar) $\pm 10\%$
Leakage	External: zero Internal: Soft seat = zero
Connection sizes	½" to 1"; 6mm to 25mm
Life Cycles	In excess of 100,000 cycles

* Consult factory for other materials

** Limited to +400° F (204° C) for ¾" / 12 mm sizes and higher

fluid control

CVH Series

Specifications

Operating Temperatures

Seal Material	Temperature (°F)	Temperature (°C)
Viton®	-20° to +400°	-29° to +204°
Fluorosilicone	-80° to +350°	-62° to +177°
Kalrez®*	-40° to +550°	-40° to +288°
Buna N	-65° to +275°	-54° to 135°

* Limited to +400° F (204° C) for 3/4" / 12 mm sizes and higher

Flow Rates

Fitting Size	1/8"	1/4"/4mm	3/8"/6mm	1/2"/8mm	10mm	3/4"/12mm	1"/16mm
fitting code*	-02	-04	-06	-08	-10	-12	-16
Cv FACTORS	0.32	0.79	1.71	3.08	3.87	7.38	7.38

* See ordering matrix on page 9

Materials of Constructions

Part	Standard Materials (Others on Request)
1 Body* (inlet)	316 stainless steel
2 Body* (outlet)	316 stainless steel
3 Poppet*	316 stainless steel
4 Spring*	302 stainless steel
5 O-ring*	Viton®
6 Spring guide	316 stainless steel
7 O-ring†	Viton®

* wetted component

† Applies to 3/4" / 12mm sizes and higher

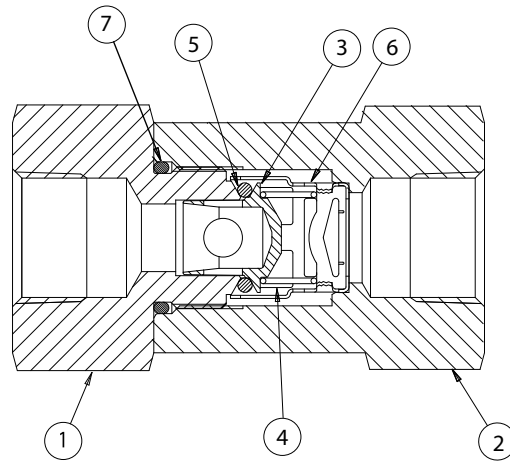

Dimensions

GYROLOK® Tube Fitting, Fractional

Fitting Code*	Fitting Size	A	B	C	D	E	F	G
-02	1/8"	0.93	0.20	0.67	1.33	0.19	1.06	0.44
-04	1/4"/4mm	0.93	0.20	0.77	1.33	0.19	1.06	0.56
-06	3/8"/6mm	1.33	0.20	0.83	1.73	0.39	1.44	0.69
-08	1/2"/8mm	1.33	0.20	0.92	1.73	0.42	1.44	0.88
-12	3/4"/12mm	2.05	0.50	0.97	3.05	0.66	2.25	1.25
-16	1"/16mm	2.05	0.50	1.08	3.05	0.66	2.25	1.5

* See ordering matrix on page 9

GYROLOK® Tube Fitting, Metric

Fitting Code*	Fitting Size	A	B	C	D	E	F	G
-04	1/4"/4mm	23.62	5.08	17.9	33.78	2.44	26.99	12.70
-06	3/8"/6mm	23.62	5.08	19.5	33.78	3.96	26.99	14.22
-08	1/2"/8mm	23.62	5.08	19.1	33.78	5.94	26.99	15.88
-10	10mm	33.78	5.08	19.8	43.94	8.03	36.51	19.05
-12	3/4"/12mm	33.78	5.08	23.4	43.94	10.01	36.51	22.23
-14	14mm	33.78	5.08	21.0	43.94	12.01	36.52	25.40
-16	1"/16mm	52.07	12.70	23.4	77.47	12.70	57.15	25.40
-18	18mm	52.07	12.70	24.6	77.47	15.88	57.15	28.58
-22	22mm	52.07	12.70	24.6	77.47	16.66	57.15	31.75
-25	25mm	52.07	12.70	27.4	77.47	16.66	57.15	38.10

* See ordering matrix on page 9

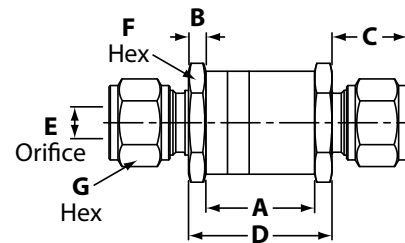

CVH Series

Dimensions

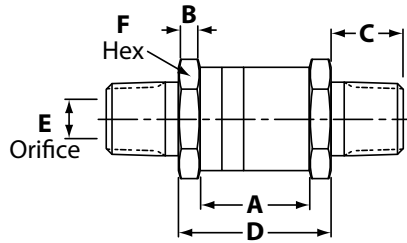

Male NPT, (Fractional)

Fitting Code*	Fitting Size	A	B	C	D	E	F
-02	1/8"	0.93	0.20	0.38	1.33	0.19	1.06
-04	1/4"/4mm	0.93	0.20	0.56	1.33	0.19	1.06
-06	3/8"/6mm	1.33	0.20	0.56	1.73	0.39	1.44
-08	1/2"/8mm	1.33	0.20	0.75	1.73	0.42	1.44
-12	3/4"/12mm	2.05	0.50	0.75	3.05	0.66	2.25
-16	1"/16mm	2.05	0.50	0.94	3.05	0.66	2.25

* See ordering matrix on page 9

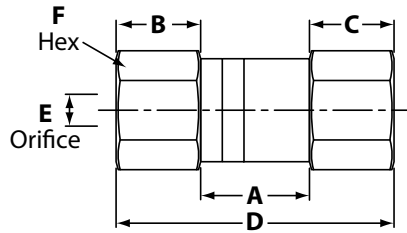

Female NPT, (Fractional)

Fitting Code*	Fitting Size	A	B Inlet	C Outlet	D	E	F
-02	1/8"	0.93	0.62	0.65	2.20	0.19	1.06
-04	1/4"/4mm	0.93	0.62	0.88	2.43	0.19	1.06
-06	3/8"/6mm	1.33	0.78	0.78	2.89	0.39	1.44
-08	1/2"/8mm	1.33	0.93	0.98	3.24	0.42	1.44
-12	3/4"/12mm	2.05	1.08	0.95	4.08	0.66	2.25
-16	1"/16mm	2.05	1.37	1.16	4.58	0.66	2.25

* See ordering matrix on page 9

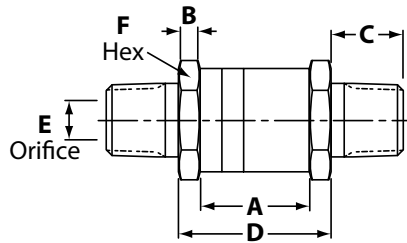

Male British Tapered Pipe, (Fractional)

Fitting code*	Fitting Size	A	B Inlet	C Outlet	D	E	F
-02	1/8"	0.93	0.20	0.38	1.33	0.19	1.06
-04	1/4"/4mm	0.93	0.20	0.56	1.33	0.19	1.06
-06	3/8"/6mm	1.33	0.20	0.56	1.73	0.39	1.44
-08	1/2"/8mm	1.33	0.20	0.75	1.73	0.42	1.44
-12	3/4"/12mm	2.05	0.50	0.75	3.05	0.66	2.25
-16	1"/16mm	2.05	0.50	0.94	3.05	0.66	2.25

* See ordering matrix on page 9

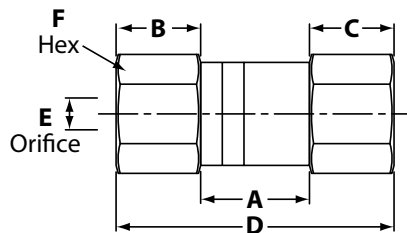

Female British Tapered Pipe, (Fractional)

Fitting Code*	Fitting Size	A	B Inlet	C Outlet	D	E	F
-02	1/8"	0.93	0.63	0.64	2.20	0.19	1.06
-04	1/4"/4mm	0.93	0.88	0.89	2.70	0.19	1.06
-06	3/8"/6mm	1.33	0.98	0.97	3.28	0.39	1.44
-08	1/2"/8mm	1.33	1.25	1.24	3.82	0.42	1.44
-12	3/4"/12mm	2.05	1.58	1.22	4.85	0.66	2.25
-16	1"/16mm	2.05	1.80	1.46	5.31	0.66	2.25

* See ordering matrix on page 9

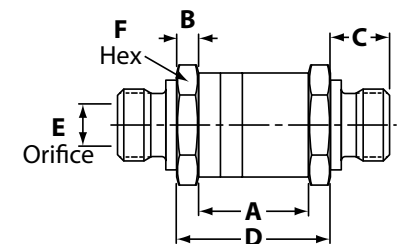

Male British Parallel Pipe, (Fractional)

Fitting Code*	Fitting Size	A	B	C	D	E	F
-02	1/8"	0.93	0.20	0.38	1.33	0.19	1.06
-04	1/4"/4mm	0.93	0.20	0.56	1.33	0.19	1.06
-06	3/8"/6mm	1.33	0.20	0.56	1.73	0.39	1.44
-08	1/2"/8mm	1.33	0.20	0.75	1.73	0.42	1.44
-12	3/4"/12mm	2.05	0.50	0.75	3.05	0.66	2.25
-16	1"/16mm	2.05	0.50	0.94	3.05	0.66	2.25

* See ordering matrix on page 9

CVH Series

Dimensions

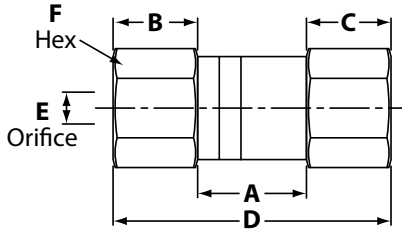

Female British Parallel Pipe, (Fractional)

Fitting Code*	Fitting Size	A	B Inlet	C Outlet	D	E	F
-02	1/8"	0.93	0.66	1.05	2.64	0.19	1.06
-04	1/4"/4mm	0.93	0.89	1.06	2.88	0.19	1.06
-06	3/8"/6mm	1.33	1.04	0.96	3.33	0.39	1.44
-08	1/2"/8mm	1.33	1.17	1.20	3.70	0.42	1.44
-12	3/4"/12mm	2.05	1.51	1.17	4.73	0.66	2.25
-16	1"/16mm	2.05	1.61	1.37	5.03	0.66	2.25

* See ordering matrix below

How to Order

Standard items in bold

CVH G 4 Y 3 1 S - IS

FITTING TYPE

- F Female NPT
- G **GYROLOK® tube fitting, fractional**
- J Male British parallel pipe
- K Female British parallel pipe
- M Male NPT
- Q Male British tapered pipe
- T Female British tapered pipe
- Z GYROLOK® tube fitting, metric

FITTING SIZE

	Fractional	Metric
2	1/8"	N/A
4	1/4"	4mm
6	3/8"	6mm
8	1/2"	8mm
10	N/A	10mm
12	3/4"	12mm
14	N/A	14mm
16	1"	16mm
18	N/A	18mm
22	N/A	22mm
25	N/A	25mm

BODY MATERIAL

- Y 316 stainless steel (standard)**
- H HASTELLOY® C-276
- M MONEL® R-405 (Comes with Inconel Spring)
- TI Titanium (Comes with Inconel Spring)
- D50 2507 Super Duplex SST
- 6MO 254 SMO SST
- DX3 2205 Duplex SST
- 625 Inconel 625 (Comes with Inconel Spring)
- 825 Inconel 825 (Comes with Inconel Spring)

ADDITIONAL OPTIONS

- IS Inconel spring**
- NK Norsok Complaint
- SLF Sulfinert Coating
- 22 Buna-N Oring (90 Duro)
- 93 HNBR Oring (90 Duro)

CLEANING OPTIONS

- S Standard**
- O Oxygen cleaning

SEAL MATERIALS

- 1 Viton®
- 2 Buna-N (not for oxygen service)
- 3 Fluorosilicone
- 4 Kalrez® 4079
- 5 Kalrez® 6375 Oring
- 6 EPDM

CRACK PRESSURE

- 1 0.5 psig (0.034 bar)
- 2 1.0 psig (0.07 bar)
- 3 3.0 psig (0.21 bar)
- 4 10 psig (0.70 bar)
- 5 20 psig (1.38 bar)
- 6 0.33 psig (0.023 bar)
- 7 5.0 psig (0.345 bar)
- 8 2.0 psig (0.14 bar)

Please consult HOKE® or your local distributor for information on special connections, o-rings, operating pressures and temperature ranges.

GYROLOK® is a registered trademark of HOKE®.
 MONEL® is a registered trademark of Special Metals Corporation.
 HASTELLOY® is a registered trademark of Haynes International, Inc.
 Kalrez® and Viton® are registered trademarks of DuPont Dow Elastomers.



XVH Series

Excess Flow Valves



XVH Series Excess Flow Valves act as flow switches that automatically close when a flow spike occurs, preventing uncontrolled release of system fluid. The XVH Series is available in automatic and manual reset versions, depending on system requirements. Automatic reset XVH Series have an “anti-clog” wire which increases reliability by preventing a build up of system fluid in the bleed port. The XVH Series are high pressure (0 to 6000 psig [414 bar]), high performance, quick acting, zero leakage, low maintenance excess flow valves that will help provide a reliable and safe working environment.

- Lower cost
- Versatile
- Reliable
- Safety
- Flexible

Features

Automatic reset

- The bleed vent allows the valve to automatically reset

Manual reset

- Zero leakage: the valve must be manually reset

2-piece design

- Allows for simple spring and seal maintenance

O-ring or metal seat

- Can be used with any liquid or gas service

Various body materials

- Can be used with any liquid or gas service

Various end connections

- Can be assembled in any system or application

Spring-loaded poppet

- Can be mounted in any orientation

Anti-clog wire

- Prevents clogging of bleed port
- Special High Tolerance NPT Thread

Technical Data

Body Material*	316 stainless steel, MONEL®, HASTELLOY® C-276, 254 SMO
Temperature Range	-320° to +900° F (-196° to +482° C)
Operating Pressure	Zero to 6000 psig (414 bar)
Leakage Rate	<ul style="list-style-type: none">• External: zero leak• Internal soft seat: zero leak
Flow/Trip Point Ranges	Low, standard/low, medium, and high

* Consult factory for other materials

fluid control

XVH Series

Function

Excess Flow Valves are designed to limit flow of fluid to a predetermined rate. When flow reaches a predetermined rate the poppet will close, limiting or stopping flow. When pressure is equalized across the valve, the poppet will reset to the open position.

Open Position

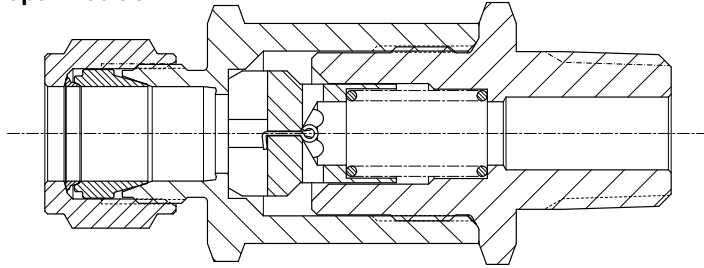

The spring holds the poppet in the open position during normal flow. When flow increases to the predetermined rate or trip point, the poppet will close.

Manual Reset

The poppet will remain in the tripped position with zero leakage and zero flow until pressure is manually equalized across the poppet. When the pressure becomes equal, the spring will then reset the poppet to the open position, allowing normal flow.

Tripped Position

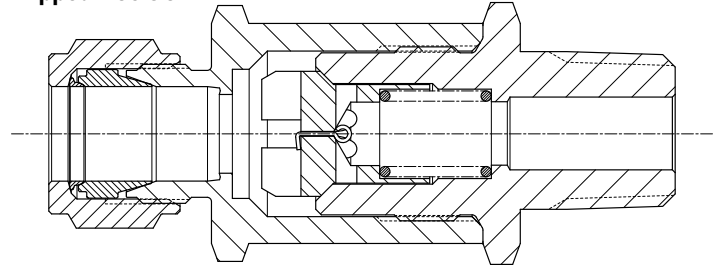

Automatic Reset

The poppet will remain in the tripped position until system pressure becomes equal across the poppet. The bleed orifice in the poppet will allow the pressure to slowly equalize across the valve if the downstream line is closed or repaired. When the pressure becomes equal, the spring will then reset the poppet to the open position, allowing normal flow.

Materials of Construction

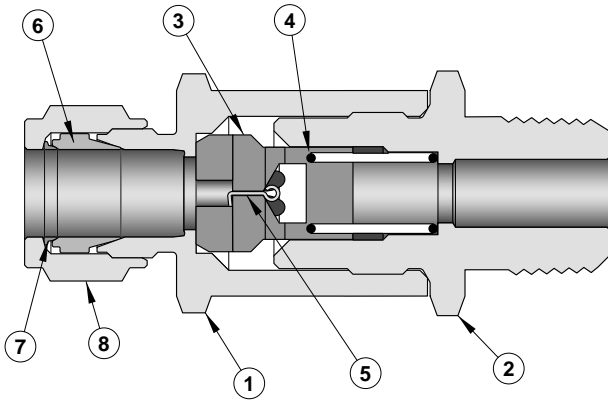

Part	Standard Material (others available on request)
1 Body* (outlet)	316 stainless steel
2 End adapter* (inlet)	316 stainless steel
3 Poppet*	316 stainless steel
4 Spring*	302 stainless steel or INCONEL®**
5 Anti-clog wire*	302 stainless steel
6 Front ferrule*	316 stainless steel
7 Rear ferrule	316 stainless steel
8 Nut	316 stainless steel

* Wetted component

** INCONEL® springs installed with 254 SMO, (-65) Kalrez®, and (-00) seals, HASTELLOY C®.

Operating Temperatures

Soft Seal, Manual Reset Valve

O-ring Code	O-ring Material	Temperature	
		°F	°C
-32	Viton®	-20° to +400°	-29° to +204°
-62	Ethylene propylene	-65° to +300°	-54° to +149°
-64	Fluorosilicone	-80° to +350°	-62° to +177°
-65	Kalrez®	-40° to +550°	-40° to +288°

XVH Series

Water Flow Rates: Standard

Using the graph below, look up your desired normal flow rate (including normal surges) on the X axis. Read vertically on the graph to the Cv line and then left on the graph from the Cv line to the pressure drop. Then select a valve and trip range higher than normal expected flow. For example: With a normal flow rate of 1 GPM, a 1/4" valve (XVH-4) will have a pressure drop of approximately 6.5 psi. Selecting a 1/4" valve with a medium trip option, the valve will close when the flow reaches 1.5 GPM and a pressure drop of approximately 15 psi.

Water Flow – Standard Inlet/Outlet Sizes = 1/4", 6mm, 8mm

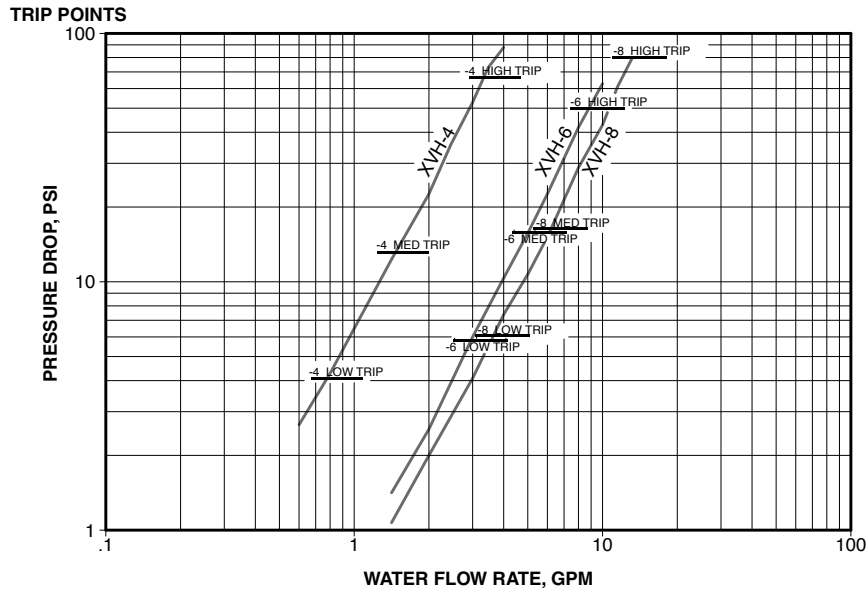

Note:
XVH-4 is inlet/outlet size of 1/4"
XVH-6 is inlet/outlet size of 6mm
XVH-8 is inlet/outlet size of 8mm

Air Flow Rates – Standard

Using the graphs below, find the intersection of your normal flow rate (including normal surges) and the inlet pressure of the excess flow valve. From there, move to the right on the graph and select a valve with a trip range greater than your normal flow. For example: reading the chart below, if normal flow is 20 scfm and the inlet pressure is 200 psig, you would select a 1/4" valve with a medium trip range.

Air Flow – Standard Inlet/Outlet Sizes = 1/4", 6mm, 8mm

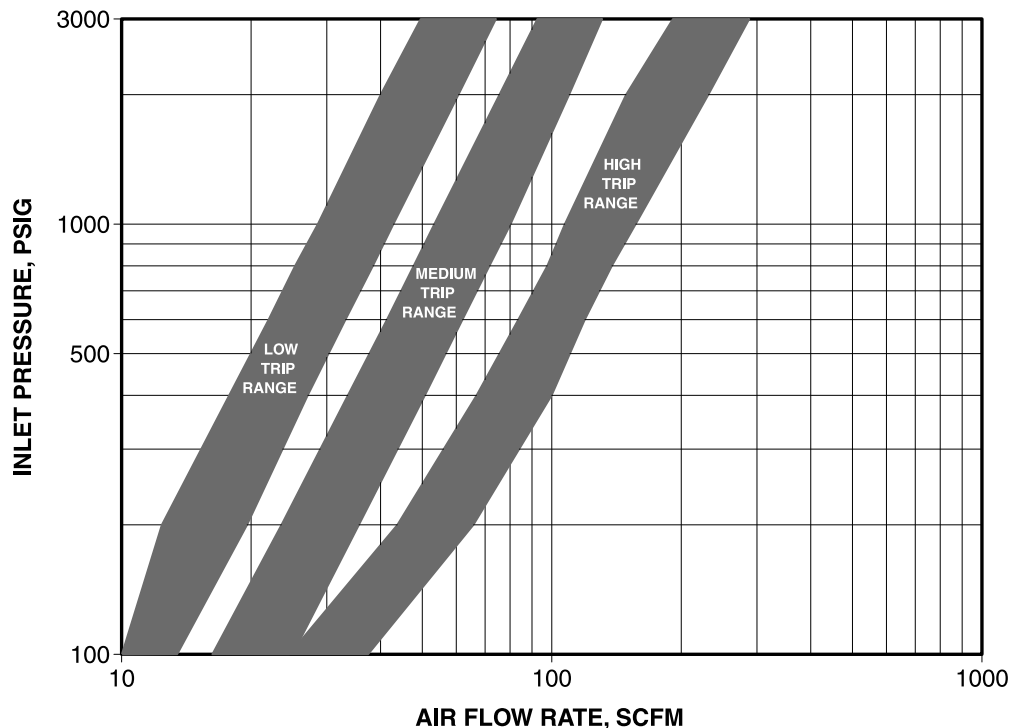

XVH Series

Air Flow –Standard Inlet/Outlet Sizes = $\frac{3}{8}$ " , 10mm

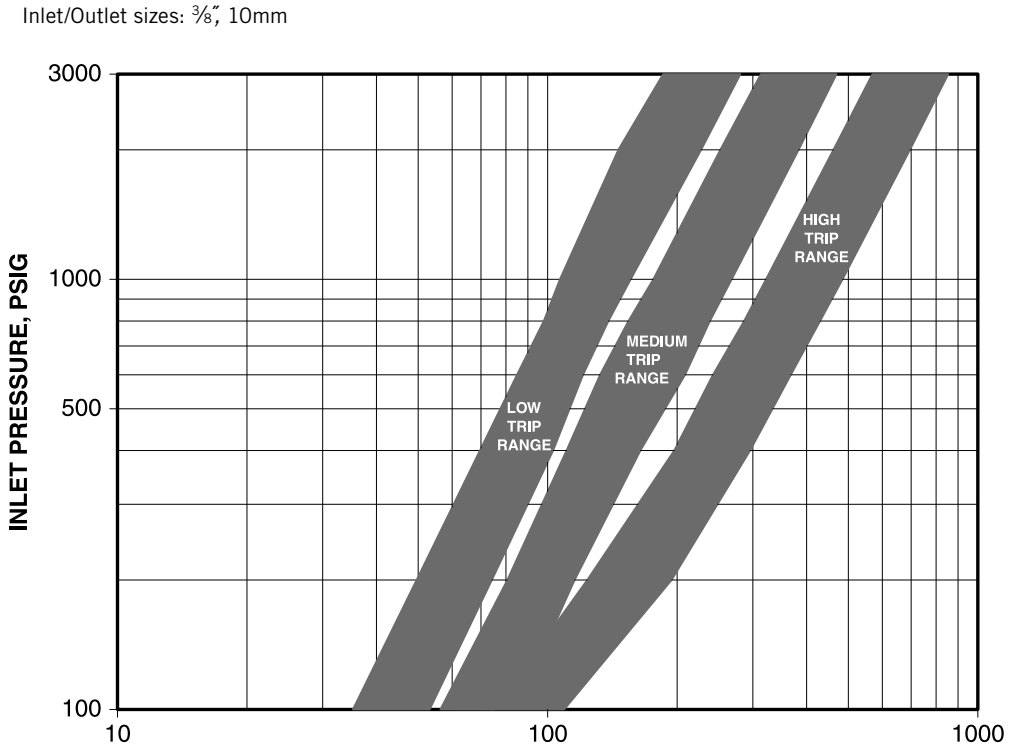

Air Flow –Standard Inlet/Outlet Sizes = $\frac{1}{2}$ " , 12mm

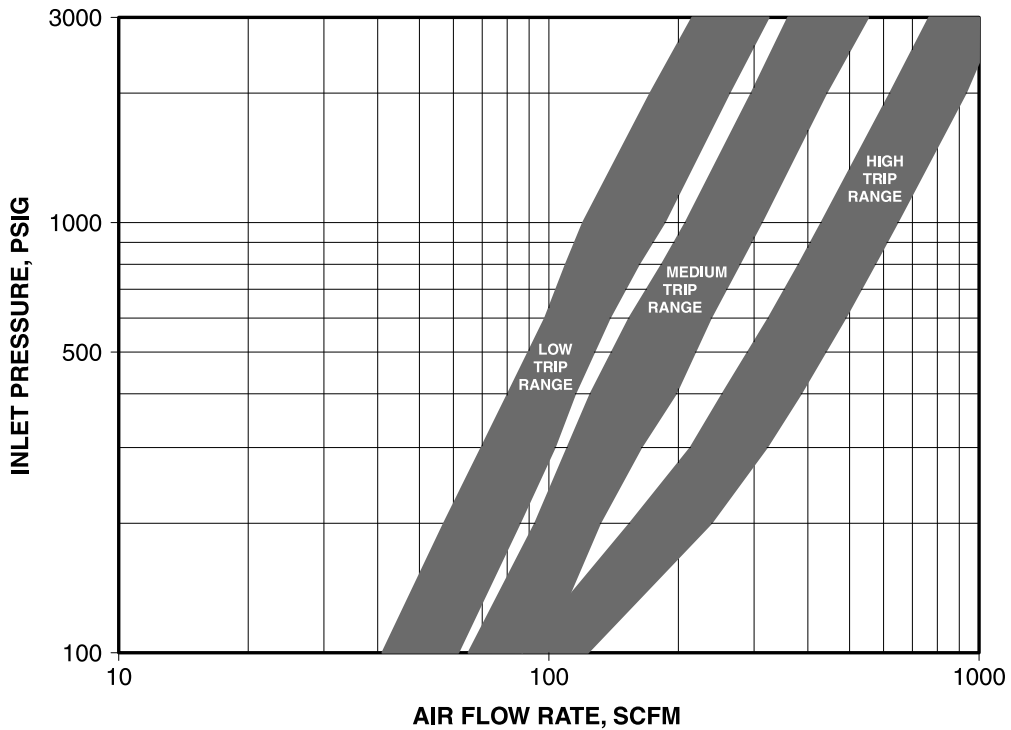

XVH Series

How to Order

Standard items in bold

XVH Y 08 M 08 G 00 100

BODY MATERIAL

- Y 316 stainless steel (standard)**
- M MONEL®
- H HASTELLOY® C-276
- O 254 SMO

INLET SIZE

- 04 ¼" (standard)**
- 06 6mm, ⅜" (standard)**
- 08 8mm, ½" (standard)**
- 10 10mm
- 12 12mm

INLET STYLE

- G GYROLOK® tube fitting (standard)**
- A GYROLOK® tube adapter (standard)
- Z GYROLOK® tube fitting, metric
- W GYROLOK® tube adapter, metric
- S Male SAE
- R Female SAE
- L Male British parallel pipe
- M Male NPT (standard)**
- F Female NPT (standard)**
- Q Male British tapered pipe
- P Female British tapered pipe

OUTLET SIZE

- 04 ¼" (standard)**
- 06 6mm, ⅜" (standard)**
- 08 8mm, ½" (standard)**
- 10 10mm
- 12 12mm

TRIP POINT

- Standard Flow*
- 100 Low
- 200 Medium
- 300 High (standard)

Low Flow

- 010 Low
- 020 Medium
- 030 High

O-RING MATERIAL

- Automatic Reset
- 00 No o-ring (metal-to-metal seat)

Manual Reset

- 32 Viton®
- 62 Ethylene propylene
- 65 Kalrez®

OUTLET STYLE

- G GYROLOK® tube fitting (standard)**
- A GYROLOK® tube adapter (standard)
- Z GYROLOK® tube fitting, metric
- W GYROLOK® tube adapter, metric
- S Male SAE
- R Female SAE
- L Male British parallel pipe
- M Male NPT (standard)**
- F Female NPT (standard)**
- Q Male British tapered pipe
- P Female British tapered pipe

Note: Inlet and outlet fittings can be the same or mixed styles.

GYROLOK® is a registered trademark of HOKE®.
 MONEL® is a registered trademark of Special Metals Corporation.
 Kalrez® and Viton® are registered trademarks of DuPont Dow Elastomers.
 HASTELLOY® is a registered trademark of Haynes International, Inc.



6100 & 6200 Series

Ball and Poppet Check Valves



Features

- O-ring seat provides leak-tight shutoff
- Internal design guides flow around or inside spring, not through coils, when valve is open
- All models are tested in production to assure a leak-tight body joint and seat
- Ball and poppet designs are available as standard
- Ball type provides effective leak-tight closure with minimum flow resistance
- Poppet models provide large flows with a minimum of chatter and fluctuation
- Valves are available with various cracking pressures, from 1/8 to 25 psig (0 to 2 bar).
- 2-piece body permits interchangeability of end connections
- Special High Tolerance NPT Thread

Applications

- Prevents reversed flow to protect solenoids, regulators, and pumps
- Locks pressure in hydraulic cylinders
- Low pressure inline relief valve
- Vent valve to purge a system

Technical Data

Body Material*	316 stainless steel, brass, MONEL®
Maximum Operating Pressure	Brass: 3000 psig @ 70° F (206.84 bar @ 21° C) Stainless steel, MONEL®: 6000 psig @ 70° F (414 bar @ 21° C)
Standard cracking pressure	2 psig
Operating Temperature Range	Buna N: -40° F to +200° F (-40° C to +93° C) Viton®: -20° F to +350° F (-29° C to +177° C)
Orifice Sizes	0.187" (4.75mm), 0.422" (10.7mm)
Cv Factors	0.3, 2.4

* Consult factory for other materials

fluid control

6100 & 6200 Series

Materials of Construction

Part	Ball Type			Poppet Type
	Brass	316 Stainless Steel	MONEL®	316 Stainless Steel
Body	Brass	316 stainless steel	MONEL®	316 stainless steel
Ball/Poppet	302 stainless steel	316 stainless steel	MONEL®	316 stainless steel
Spring	302 stainless steel	316 stainless steel	MONEL®	316 stainless steel
O-ring seat	Buna N	Viton®	Viton®	Viton®/Buna N*
Gasket (body)	Mylar®	PTFE	PTFE	PTFE/Buna N*

* For poppet check valves with 3/8" and 1/2" NPT female connections.

Dimensions

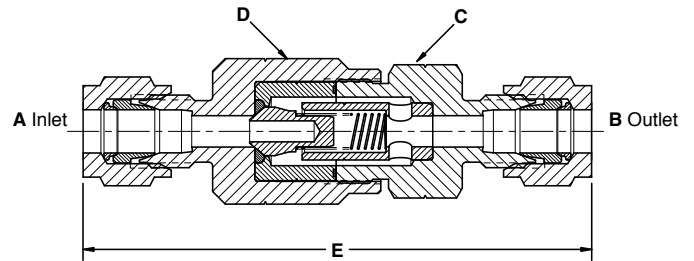
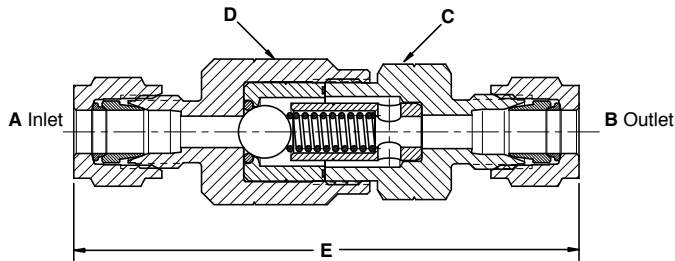

6100 Series Ball Check Valves

A & B Connections		C Hex	D Hex	E
1/8" NPT female	inch	1 1/16	3/4	2 3/4
	mm	17	19	60
1/8" NPT male	inch	1 1/16	3/4	2 3/4
	mm	17	19	60
1/4" NPT female	inch	3/4	3/4	2 1/2
	mm	19	19	64
1/4" NPT male	inch	1 1/16	3/4	2 3/4
	mm	17	19	60
1/4" NPT male x 1/4" GYROLOK®	inch	1 1/16	3/4	2 3/4
	mm	17	19	70
6mm GYROLOK®	inch	1 1/16	3/4	3
	mm	17	19	76
1/4" GYROLOK®	inch	1 1/16	3/4	3
	mm	17	19	76
3/8" GYROLOK®	inch	1	3/4	3 1/2
	mm	25	19	79

6200 Series Poppet Check Valves

A & B Connections		C Hex	D Hex	E
1/4" NPT female	inch	3/4	3/4	2 1/2
	mm	19	19	64
1/4" NPT male	inch	1 1/16	3/4	2 3/4
	mm	17	19	60
1/4" GYROLOK®	inch	1 1/16	3/4	3
	mm	17	19	76
3/8" GYROLOK®	inch	1	3/4	3 1/2
	mm	25	19	79
1/2" NPT female	inch	1 1/4	1 1/4	4 1/2
	mm	32	32	105

6100 & 6200 Series

Flow Diagrams

Air

For all models except 3/8" and 1/2" NPT female

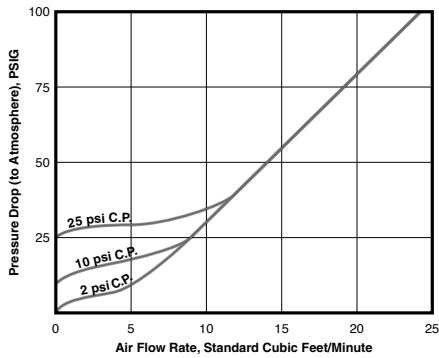

3/8" and 1/2" NPT female models

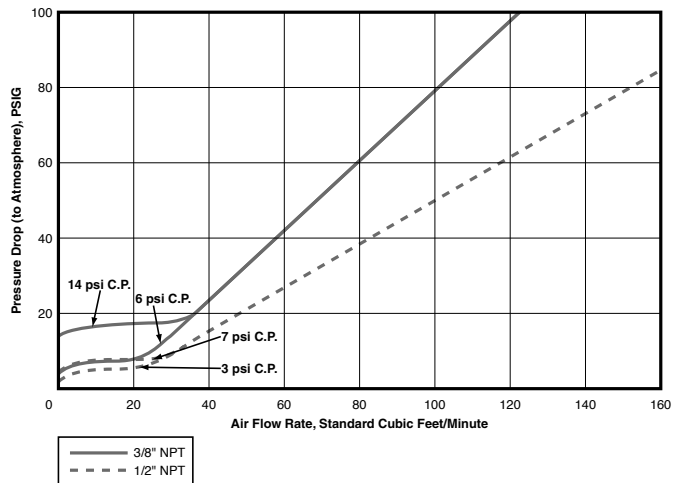

Water

For all models except 3/8" and 1/2" NPT female

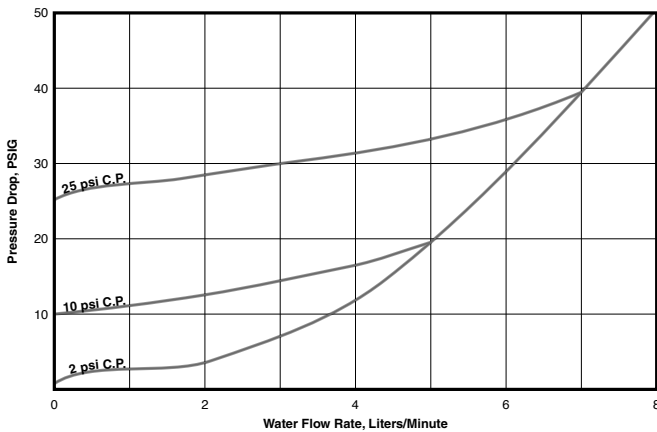

3/8" and 1/2" NPT female models

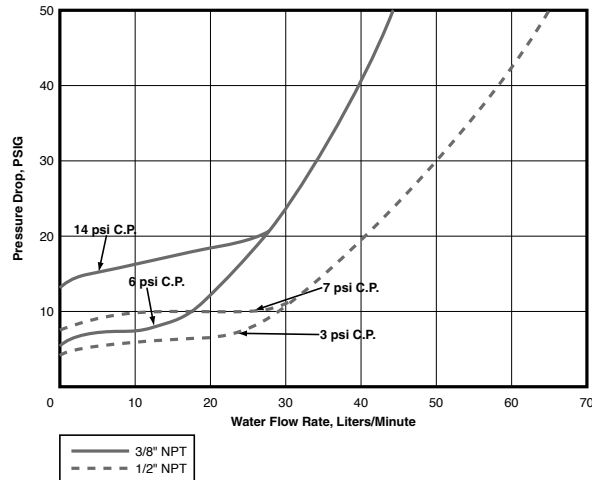

How to Order: Standard Valves (factory preset at cracking pressure of 2 psig)

6100 Series Ball Check Valves

A & B Connections	Part Number			
	Brass	MONEL®	316 St. Steel	Orifice
1/8" NPT female	6113F2B	—	6133F2Y	0.187
1/8" NPT male	6113M2B	—	6133M2Y	0.187
1/4" NPT female	6113F4B	—	6133F4Y	0.187
1/4" NPT male	6113M4B	—	6133M4Y	0.187
1/4" GYROLOK®	6113G4B	6133G4M	6133G4Y	0.187
3/8" GYROLOK®	6113G6B	6133G6M	6133G6Y	0.187
1/4" NPT male x 1/4" GYROLOK®	6113H4B	—	—	0.187
GYROLOK®	—	—	6133G6YMM	0.187

6200 Series Poppet Check Valves

A & B Connections	Part Number	
	316 St. Steel	Orifice
1/4" NPT female	6233F4Y	0.187
1/4" NPT male	6233M4Y	0.187
1/4" GYROLOK®	6233G4Y	0.187
3/8" GYROLOK®	6233G6Y	0.187
1/2" NPT female	6253F8Y	0.422
GYROLOK®	6253G8Y	0.422

Other Differential Cracking Pressures

Cracking Pressure	Digit	All check valves except 3/8" and 1/2" female NPT models can be furnished with other than the standard 2 psig cracking pressure. To order, change the fourth digit ("–3") of the desired valve part number.
1/2 psig	–1	
10 psig	–5	
25 psig	–6	

Example: **6115G4B** is a 6100 Series brass ball check valve with 1/4" GYROLOK® ends and a 10 psig cracking pressure

GYROLOK® is a registered trademark of HOKE®.

Viton® is a registered trademark of DuPont Dow Elastomers.

MONEL® is a registered trademark of Special Metals Corporation.

Mylar® is a DuPont Teijin Films registered trademark for its polyester film.



R6000 Series

Right Angle Relief Valve

Available in low, medium, high and extra high pressure models, R6000 right angle relief valves provide users with high accuracy and consistency of cracking and reseal pressures. Furthermore, narrow pressure ranges (cracking pressures) for each model can be factory pre-set according to customer specifications. PED certification and CE marking are standard for all models. All R6000 relief valves are offered with multiple end connections to ensure application versatility.

Features & Benefits

Low Pressure (5 – 550 psig)*

Zero friction poppets

- Increases accuracy of cracking pressure and reseal pressure.
- Improves consistency of cracking pressure and reseal pressure.

Encapsulated Seat Seal

- Maintains small contact surface area.
- Protects seat from erosion due to flow.

Raised seal lip on poppet minimizes contact with seat, eliminating friction and preventing overstressing of the O-ring

6 pressure spring ranges improve accuracy

Caps and bonnets are pre-drilled for lockwire

Multiple end connections available

- Special High Tolerance NPT Thread

High Pressure (150–6000 psig)

3 models available:

- Medium (150–2500 psig)—6 spring ranges improve accuracy
- High (150–5000 psig)—7 spring ranges improve accuracy
- Extra High (5000–6000 psig)—one spring

Delta stem seal design prevents friction which increases accuracy of cracking pressure and reseal pressure.

Balanced poppet design allows cracking pressure to stay the same regardless of backup pressure.

Orifice sizes: 0.082", 0.094", 0.188"

Multiple end connections available.

Optional manual override handle

For European Pressure Equipment Directive (PED 2014/68/EU) applications, due to the R6000 valve's small poppet seat design, the R6000 valve is certified to be used in clean gas service ONLY (free from dust particles, contamination, etc. (gas group 1 & 2)).

* Back pressure affects cracking pressure on low pressure version



Typical Applications (Pure Gases Only For PED Applications)

- Beverage dispensing equipment
- Gas pilot plants
- Petrochemical test labs
- Offshore oil platform heating lines
- Pharmaceutical sterilization and packaging systems

fluid control

R6000 Series

Materials of Construction

LR	
1	End
2	Body
3	Shroud ring
4	Poppet
5	Bonnet
6	Jam nut
7	Cap
8	Spring holder
9	Retaining ring
10	O-ring
11	Spring
12	Spring equalizer
13	O-ring
14	Seat o-ring
15	O-ring

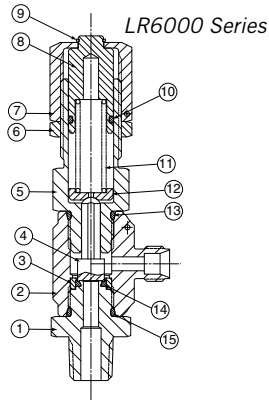

MR/HR/XR	
1	End
2	Body
3	Shroud ring
4	Poppet
5	Bonnet
6	Jam nut
7	Cap
8	Spring holder
9	Spring
10	Spring equalizer
11	O-ring
12	Delta ring
13	O-ring
14	Seat o-ring
15	O-ring

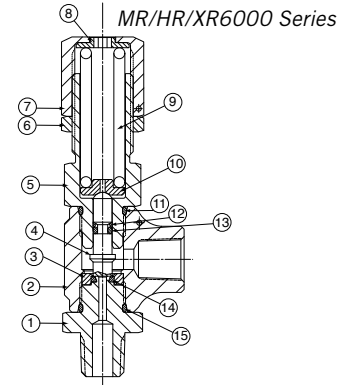

Specifications	
BODY CONSTRUCTION	316 stainless steel
SPRING MATERIAL	17-7PH CRES
SEAL MATERIAL	Viton® • Buna N • EPR • Kalrez® • Silicone (not available for the XR Series)
CONNECTION SIZES	1/4"
ORIFICE SIZE	LR6000, MR6000: 0.188" HR6000: 0.094" XR6000: 0.082"

Dimensions

Model No.	1/4" GYROLOK® x 1/4" GYROLOK®			1/4" Male NPT x 1/4" GYROLOK®			1/4" Male NPT x 1/4" Female NPT		
	A	B	C	D	E	F	G*	H	J
LR	3.10" max (7.87cm)	1.34" (3.40cm)	0.97" (2.39cm)	3.10" max (7.87cm)	1.44" (3.66cm)	0.97" (2.39cm)	n/a	1.44" (3.66cm)	1.00" (2.54cm)
MR	2.94" max. (7.47cm)	1.34" (3.40cm)	0.97" (2.39cm)	2.94" max. (7.47cm)	1.44" (3.66cm)	0.97" (2.39cm)	2.94" max. (7.47cm)	1.44" (3.66cm)	1.00" (2.54cm)
HR	2.94" max. (7.47cm)	1.34" (3.40cm)	0.97" (2.39cm)	2.94" max. (7.47cm)	1.44" (3.66cm)	0.97" (2.39cm)	2.94" max. (7.47cm)	1.44" (3.66cm)	1.00" (2.54cm)
XR	2.94" max. (7.47cm)	1.34" (3.40cm)	0.97" (2.39cm)	2.94" max. (7.47cm)	1.44" (3.66cm)	0.97" (2.39cm)	n/a	1.44" (3.66cm)	1.00" (2.54cm)

* Manual override not available for LR and XR Series

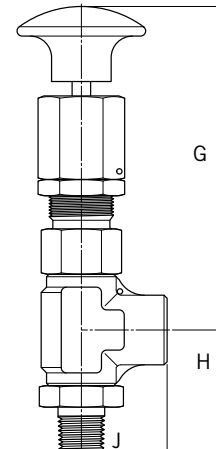
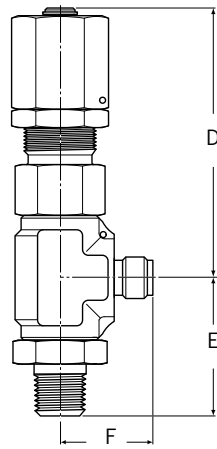
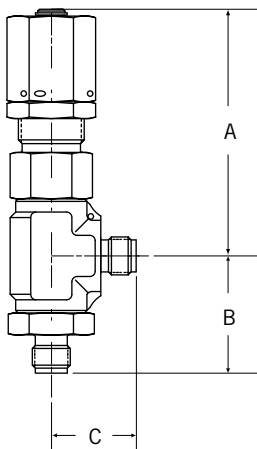

R6000 Series

Operating Pressures

Pressures	LR6000	MR6000	HR6000	XR6000
Cracking Pressure	5–550 psig (0–38 bar)	150–2500 psig (10–172 bar)	150–5000 psig (10–345 bar)	5000–6000 psig (345–414 bar)
Maximum Operating Pressure	5–700 psig (0–48 bar)	150–6000 psig (10–414 bar)	150–7000 psig (10–482 bar)	5000–7000 psig (345–482 bar)
Proof	1050 psig (72 bar)	9000 psig (620 bar)	9000 psig (620 bar)	9000 psig (620 bar)
Burst	Over 2800 psig (193 bar)	Over 24,000 psig (1655 bar)	Over 24,000 psig (1655 bar)	Over 24,000 psig (1655 bar)
Reseat Pressure	85% min. of CP > 10 psig 70% of CP < 10 psig	85% min. of CP	85% min. of CP	85% min. of CP

C_v Ratings

Cracking Pressure PSIG	C _v LR6000 0.188"		C _v MR6000 0.188"		C _v HR6000 0.094"		C _v XR6000 0.082"	
	Air	Water	Air	Water	Air	Water	Air	Water
5	0.63	0.47	—	—	—	—	—	—
25	0.63	0.47	—	—	—	—	—	—
26	0.64	0.43	—	—	—	—	—	—
80	0.64	0.43	—	—	—	—	—	—
81	0.4	0.31	—	—	—	—	—	—
150	0.4	0.31	—	—	—	—	—	—
151	0.42	0.26	0.79	0.59	0.25	0.16	—	—
250	0.42	0.26	0.79	0.59	0.25	0.16	—	—
251	0.3	0.19	0.79	0.59	0.25	0.16	—	—
350	0.3	0.19	0.79	0.59	0.25	0.16	—	—
351	0.35	0.18	0.61	0.59	0.27	0.16	—	—
550	0.35	0.18	0.61	0.59	0.27	0.16	—	—
650	—	—	0.61	0.59	0.27	0.16	—	—
651	—	—	0.38	0.29	0.27	0.16	—	—
700	—	—	0.38	0.29	0.27	0.16	—	—
701	—	—	0.38	0.29	0.2	0.16	—	—
1001	—	—	0.37	0.20	0.2	0.14	—	—
1300	—	—	0.37	0.20	0.2	0.14	—	—
1301	—	—	0.37	0.20	0.21	0.14	—	—
1500	—	—	0.37	0.20	0.21	0.13	—	—
1501	—	—	0.28	0.14	0.21	0.13	—	—
2000	—	—	0.28	0.14	0.21	0.13	—	—
2001	—	—	0.24	0.10	0.19	0.13	—	—
2500	—	—	0.24	0.10	0.19	0.13	—	—
3000	—	—	—	—	0.19	0.13	—	—
3001	—	—	—	—	0.15	0.07	—	—
4000	—	—	—	—	0.15	0.07	—	—
5000	—	—	—	—	—	—	0.15	0.009
6000	—	—	—	—	—	—	0.12	0.006

R6000 Series

Pressure/Temperature Ratings

Low Pressure

Valve No.	Seal Material	Temperature °F (°C)	Pressure Range psig (bar)
LR6032	Viton®	-20° to +400° (-29° to +204°)	Up to 25 (Up to 1.4) 26–350 (1.8–24.1) 351–550 (24.2–37.9)
LR6077	Buna-N	-65° to +275° (-54° to +135°)	Up to 25 (Up to 1.4) 26–350 (1.8–24.1) 351–550 (24.2–37.9)
LR6062	Ethylene Propylene	-65° to +300° (-54° to +149°)	Up to 25 (Up to 1.4) 26–350 (1.8–24.1) 351–550 (24.2–37.9)
LR6065	Kalrez®	-40° to +550° (-40° to +288°)	Up to 25 (Up to 1.4) 26–350 (1.8–24.1) 351–550 (24.2–37.9)
LR6024	Silicone	-70° to +450° (-57° to +232°)	Up to 25 (Up to 1.4) 26–350 (1.8–24.1) 351–550 (24.2–37.9)

Medium Pressure

Valve No.	Seal Material	Temperature °F (°C)	Pressure Range psig (bar)
MR6032	Viton®	-20° to +400° (-29° to +204°)	150–350 (10.3–24.1) 351–2500 (24.2–172.4)
MR6077	Buna-N	-65° to +275° (-54° to +135°)	150–350 (10.3–24.1) 351–2500 (24.2–172.4)
MR6062	Ethylene Propylene	-65° to +300° (-54° to +149°)	150–350 (10.3–24.1) 351–2500 (24.2–172.4)
MR6065	Kalrez®	-40° to +550° (-40° to +288°)	150–350 (10.3–24.1) 351–2500 (24.2–172.4)
MR6024	Silicone	-70° to +450° (-57° to +232°)	150–350 (10.3–24.1)

High Pressure

Valve No.	Seal Material	Temperature °F (°C)	Pressure Range psig (bar)
HR6032	Viton®	-20° to +400° (-29° to +204°)	150–300 (10.3 to 20.7) 301–5000 (20.8 to 344.8)
HR6077	Buna-N	-65° to +275° (-54° to +135°)	150–300 (10.3 to 20.7) 301–5000 (20.8 to 344.8)
HR6062	Ethylene Propylene	-65° to +300° (-54° to +149°)	150–300 (10.3 to 20.7) 301–5000 (20.8 to 344.8)
HR6065	Kalrez®	-40° to +550° (-40° to +288°)	150–300 (10.3 to 20.7) 301–5000 (20.8 to 344.8)
HR6024	Silicone	-70° to +450° (-57° to +232°)	150–300 (10.3 to 20.7)

Extra High Pressure

Valve No.	Seal Material	Temperature °F (°C)	Pressure Range psig (bar)
XR6032	Viton®	-20° to +400° (-29° to +204°)	5000–6000 (344.8–414)
XR6077	Buna-N	-65° to +275° (-54° to +135°)	5000–6000 (344.8–414)
XR6062	Ethylene Propylene	-65° to +300° (-54° to +149°)	5000–6000 (344.8–414)
XR6065	Kalrez®	-40° to +550° (-40° to +288°)	5000–6000 (344.8–414)

R6000 Series

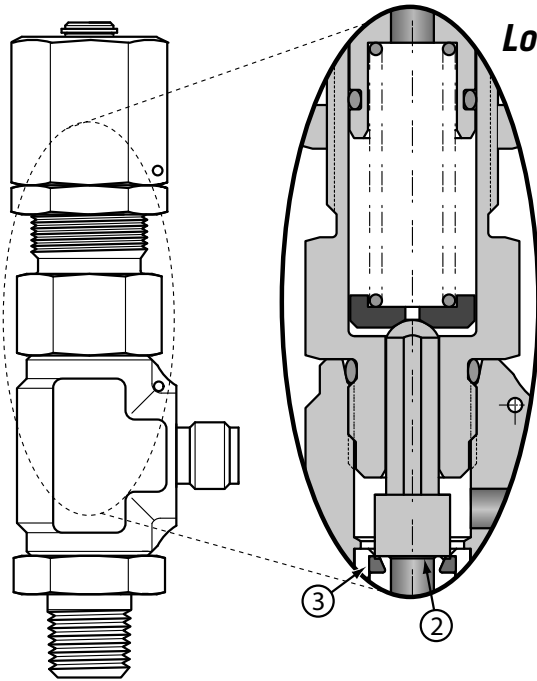

Low Pressure 5–550 psig (0–38 bar)

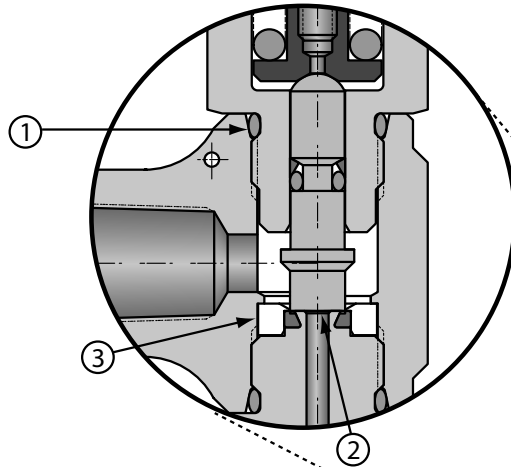

Medium Pressure 150–2500 psig
(10 – 172 bar)

High Pressure 150 – 5000 psig
(10 – 345 bar)

Extra High Pressure 5000–6000 psig
(345 – 414 bar)

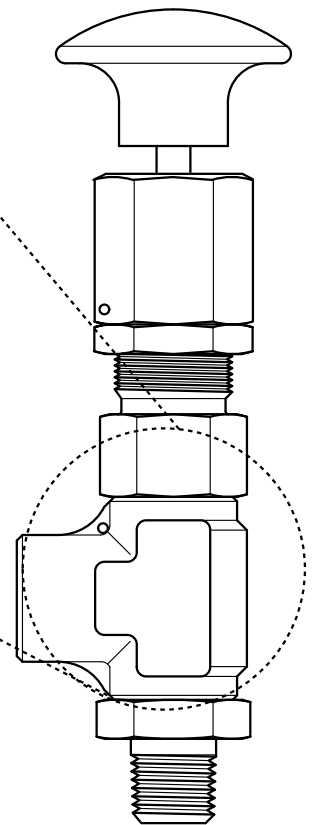

Features

① O-ring & Delta backup ring

② Raised seal lip

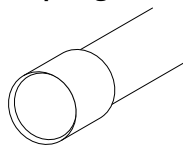

③ Fully encapsulated seat seal

R6000 Series

Crack Pressure Range

Select appropriate spring code

LR6000 Low Pressure		MR6000 Medium Pressure		HR6000 High Pressure		XR6000 Extra High Pressure	
Spring Code	Range in PSIG (BAR)	Spring Code	Range in PSIG (BAR)	Spring Code	Range in PSIG (BAR)	Spring Code	Range in PSIG (BAR)
A	5-25 (0-2)	B	150-350 (10-24)	A	150-300 (10-21)	A	5000-6000 (345-414)
B	26-80 (2-6)	C	351-650 (24-45)	B	301-700 (21-48)		
C	81-150 (6-10)	D	651-1000 (45-69)	C	701-1300 (48-90)		
D	151-250 (10-17)	E	1001-1500 (69-103)	D	1301-2000 (90-138)		
E	251-350 (17-24)	F	1501-2000 (104-138)	E	2001-3000 (138-207)		
F	351-550 (24-38)	G	2001-2500 (138-172)	F	3001-4000 (207-276)		
				G	4001-5000 (276-345)		

How to Order

LR60 24 - 2MP - A H M - * * * *

BASIC MODEL NUMBER

- LR60** Low pressure
5-550 psig (0-38 bar)
- MR60** Medium pressure
150-2500 psig (10-172 bar)
- HR60** High pressure
150-5000 psig (10-276 bar)
- XR60** Extra high pressure
5000-6000 psig (345-414 bar)

SEAL MATERIAL

- 24** Silicone*
- 32** Viton®
- 62** Ethylene propylene
- 65** Kalrez®
- 77** Buna-N

MANUAL OVERRIDE

(optional, not available for LR or XR series)
MR series only available up to 350 psig (24 bar).
HR series only available up to 700 psig (48 bar).



SPRING CODE

See Crack Pressure table above

PORT SIZE

	Inlet	Outlet
2MP	1/4" male NPT	1/4" female NPT
2M4G	1/4" male NPT	1/4" GYROLOK®
4G	1/4" GYROLOK®	1/4" GYROLOK®
2RT	1/4" BSPT male	1/4" BSPT female
6Z	6mm GYROLOK®	6mm GYROLOK®
8Z	8mm GYROLOK®	8mm GYROLOK®
12Z	12mm GYROLOK®	12mm GYROLOK®

R6000 valves are PED certified

- * Silicone seals are not available for XR series.
- * Silicone seals for MR series only available up to 350 psig (spring code B)
- * Silicone seals for HR series only available up to 300 psig (spring code A)

***Customer can request a specific cracking pressure when ordering. To specify, add the cracking pressure as -PSIG (not BAR) after the M for Manual Override (if no override, add value after "H"). Otherwise, the factory sets the valve at the nominal midpoint of the cracking pressure range selected. Valves with specific cracking pressure include standard factory installed lockwire.

R6000 Service Kits

LR Kit includes: end seat-to-body O-ring, bonnet-to-body O-ring, and bonnet seal O-ring.

MR/HR/XR Kit includes: end seat-to-body O-ring, bonnet-to-body O-ring, seat O-ring, and Delta seal. Replacement of Delta seal requires use of installation tool and resizing tool. Consult factory for details.

To Order, add **K** to front of valve part number (example: **KLR6024-2MP-AH**).

GYROLOK® is a registered trademark of HOKE®.

Kalrez® and Viton® are registered trademarks of DuPont Dow Elastomers.

www.hoke.com

www.dupontelastomers.com



6600 Series

Bleed Valves



HOKE® 6600 Series bleed valves allow for quick, easy manual bleed-off of system pressure. These valves come in a variety of configurations, including straight, elbow, union, and tee.

Features

- Compact installation
- 316 stainless steel construction
- Straight, union, elbow or tee flow configurations
- Integral tube ends
- Special High Tolerance NPT Thread

Benefits

- Safe
- Reliable
- GYROLOK® fitting connections eliminate pipe thread leak paths

Typical Applications

- Air, hydraulic systems, or natural gas
- Venting or purging of liquids and gases
- For use on instrument manifolds

Technical Data

Body Material	316 stainless steel
Maximum Operating Pressure	6000 psig @ 70° F (414 bar @ 21° C)
Operating Temperature Range	-40° F to +600° F (-40° C to +316° C)
End Connections	¼", ⅜", ½" GYROLOK®
Average Operating Torque @ Maximum Operating Pressure	40 in-lbs

Operating Instructions

- Valve is operated by turning the bleed port nut with a wrench. Use appropriate back-up wrench to hold body, while turning bleed nut.
- As the bleed nut is turned, pressure forces the ball off the seat. Pressure is vented through a hole drilled in the nut, angled back toward the body of the valve. Make sure flow is directed away from user.
- Those using the valves should wear protective clothing, especially goggles.
- No attempt should be made to repair or dismantle the valve.

fluid control

6600 Series

Dimensions

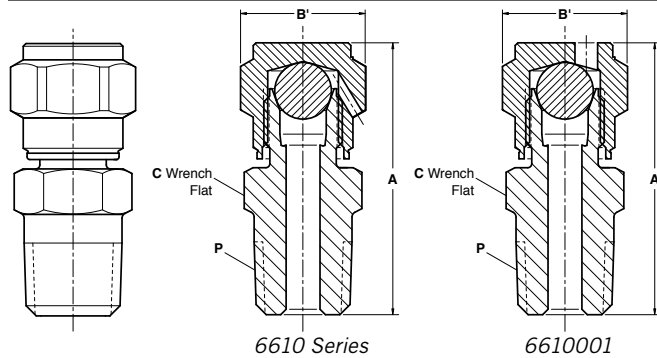

6610 Series: Straight Valve

Part Number	P Thread NPT	A Open	B' Hex	C Wrench Flat
6610M2Y	1/8"	1 3/8 (35mm)	5/8"	1/2"
6610M4Y	1/4"	1 17/32 (39mm)	5/8"	9/16"
6610M6Y	3/8"	1 19/32 (40mm)	5/8"	1 1/16"
6610M8Y	1/2"	1 13/16 (46mm)	5/8"	7/8"
6610001	1/4"	1 17/32 (39mm)	5/8"	9/16"

6631 Series Directed Bleed Valves

HOKE®'s 6631 Bleed Valve allows the user to direct the bled fluid as desired. The valve can be ordered with a 1 1/2" (38mm) press fit handle by adding an "H" suffix to the valve part number (e.g., **6631H4YH**). To operate, simply turn the 7/16" nut with a wrench or the optional loose fit stainless steel bar handle, part number **59-878**. Please consult your local distributor for details.

Caution: If the vented fluids are not going to be contained, the vent tube must be positioned at installation so that it is directed away from the operating personnel.

Technical Data

Body Material	316 stainless steel
Maximum Operating Pressure	5000 psig @ 70° F (345 bar @ 21° C)
Operating Temperature Range	-20° F to +425° F (-29° C to +218° C)
Orifice	0.125 (3.2mm)

Benefits

Safety

- O-ring packaging prevents leakage through stem threads

Reliability

- All valves are tested for bubble-tight leakage

Typical Applications

- Venting or purging of liquids and gases
- For use on gauge valves

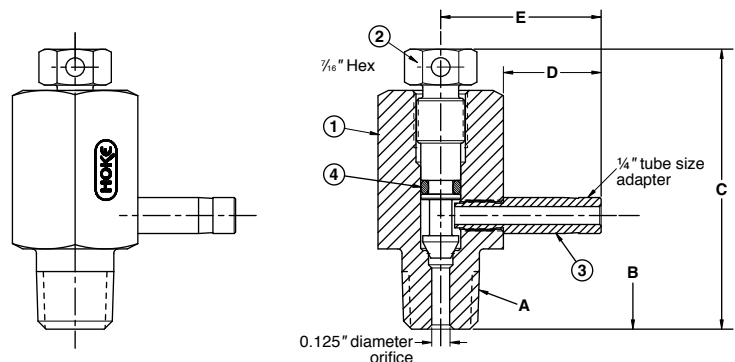

Dimension Chart

Part Number	A Inlet	B	C	D	E
6631H4Y	1/4"	3/4" (19mm)	2" (51mm)	1 1/16" (17mm)	1 3/16" (30.5mm)
6631H84Y	1/2"	2 9/32" (23mm)	2 1/8" (54mm)	1 1/16" (17mm)	1 3/16" (30.5mm)

Materials of Construction

Part	Material
1 Body	316 stainless steel
2 Stem	316 stainless steel
3 Vent tube	316 stainless steel
4 O-ring	Fluoroelastomer

GYROLOK® is a registered trademark of HOKE®.

Dimensions for reference only and are subject to change without notice.

6600 Series

Dimensions

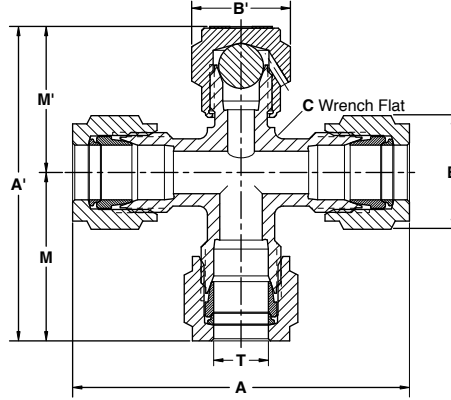
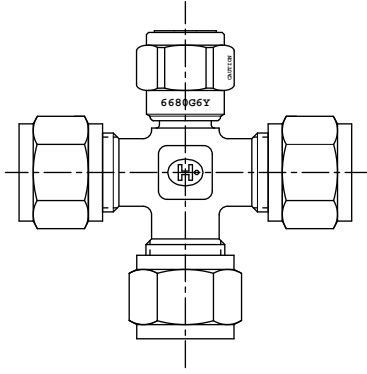

6680 Series: Tee Valve

Part Number	T Tube O.D.	A	A'	B Hex	B' Hex	C Wrench Flat	M	M'
6680G4Y	1/4"	2 5/64" (54mm)	2 5/64" (53mm)	5/16"	5/8"	7/16"	1 1/16" (27mm)	1 1/64" (27mm)
6680G6Y	3/8"	2 23/64" (60mm)	2 13/64" (52mm)	1 1/16"	5/8"	1/2"	2 3/16" (56mm)	1 1/64" (27mm)
6680G8Y	1/2"	2 57/64" (73mm)	2 13/64" (68mm)	7/8"	5/8"	1 1/16"	1 29/64" (37mm)	1 7/32" (31mm)

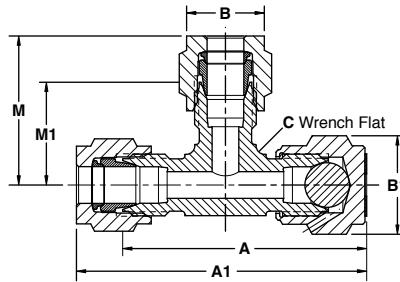
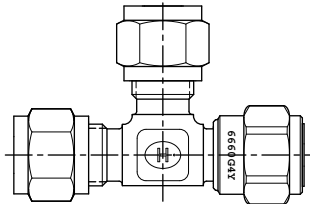

6660 Series: Elbow Valve

Part Number	T Tube O.D.	A	A'	B Hex	B' Hex	C Wrench Flat	M	M'
6660G4Y	1/4"	1 29/32" (45mm)	2 1/64" (52mm)	5/16"	5/8"	7/16"	1 3/64" (27mm)	2 3/32" (18mm)

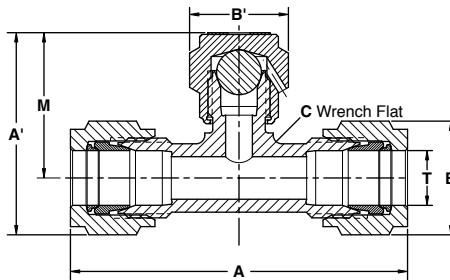
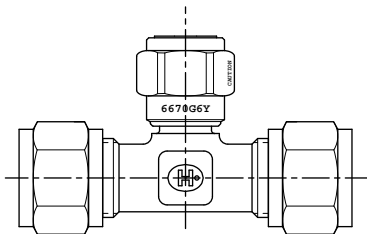

6670 Series: Union Valve

Part Number	T Tube O.D.	A	A'	B Hex	B' Hex	C Wrench Flat	M
6670G4Y	1/4"	2 3/32" (53mm)	1 23/64" (35mm)	5/16"	5/8"	7/16"	1 3/64" (27mm)
6670G6Y	3/8"	2 21/64" (59mm)	1 1/16" (37mm)	1 1/16"	5/8"	1/2"	1 3/32" (28mm)
6670G8Y	1/2"	2 57/64" (73mm)	1 21/32" (42mm)	7/8"	5/8"	1 1/16"	1 1/32" (31mm)



6300 Series

Micron Filters

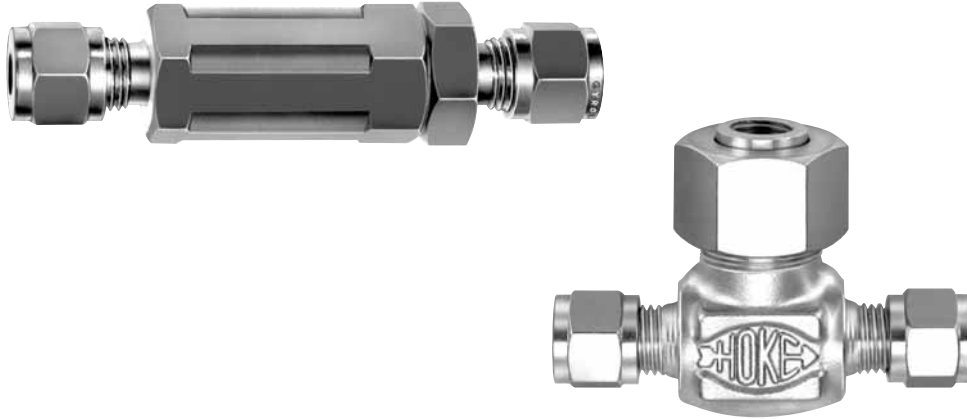

Features

- Choice of in-line, removable, or bypass filter models
- NPT female and GYROLOK® tube fitting connections
- Variety of micron filtering ranges from 2 to 55 μ
- Filter elements are available in 316 stainless steel
- Filter elements are easily replaced
- Bypass models permit purging and sampling of process fluid
- Bodies available in brass and 316 stainless steel
- Special High Tolerance NPT Thread

Applications

- Trap foreign particles
- Protect sensitive equipment
- System purging
- Pressure damper

Technical Data

Body Material	316 stainless steel, brass
Maximum Operating Pressure	Brass: 3000 psig @ 70° F (211 kg/cm ² @ 21° C) Stainless steel: 5000 psig @ 70° F (352 kg/cm ² @ 21° C)
Operating Temperature Range	-60° F to +450° F (-51° C to +232° C)
Micron Range	2 to 55 μ
Cv Factor Range	0.006 to 0.42

fluid control

6300 Series

Diagrams & Flow Curves

Water

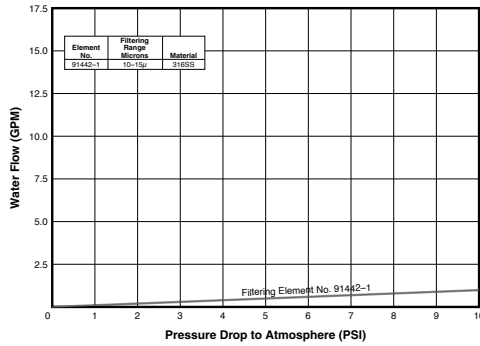
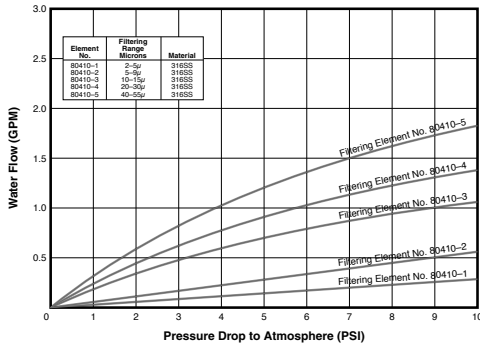

Air

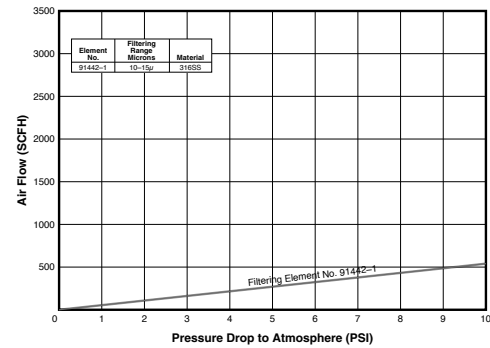
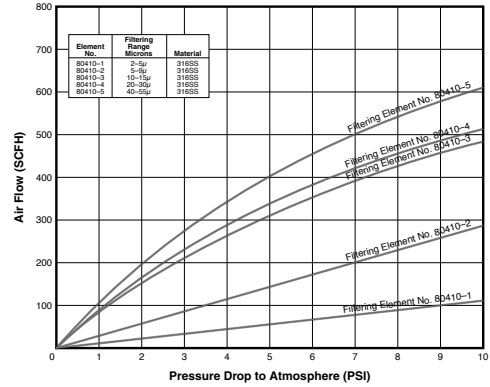

How to Order

Select and specify filter by part number, according to desired connections and materials of construction. Be sure to add the identifying digit of the desired filter element to the filter part number from the chart below. To order a 316 stainless steel in-line type, 1/8" NPT female filter with an element range of 5 to 9μ, add "-2" (e.g., **6312F2Y**). To order a filter without a filter element, insert the number "-0" in the model number desired (e.g., **6310F2Y**).

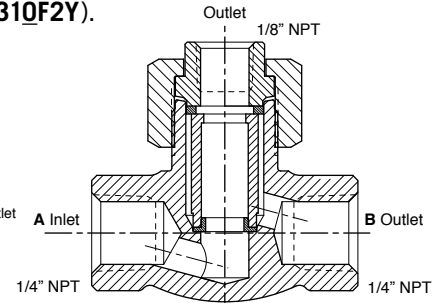
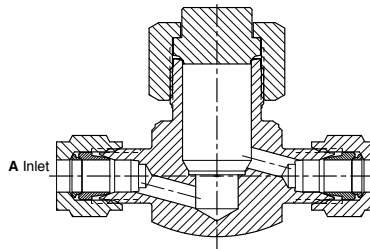
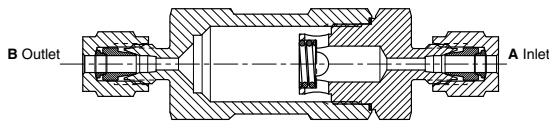

6310 Series: In-line Filters

A & B Connections	Brass	316 Stainless Steel
1/8" NPT female	631xF2B	631xF2Y
1/4" NPT female	631xF4B	631xF4Y
1/8" GYROLOK®	—	631xG2Y
1/4" GYROLOK®	631xG4B	631xG4Y

6320 Series: Removable Filters

A & B Connections	Brass	316 Stainless Steel
1/8" GYROLOK®	632xG2B	632xG2Y
1/4" NPT female	632xF4B	632xF4Y
1/4" GYROLOK®	632xG4B	632xG4Y
6mm GYROLOK®	—	632xG6YMM

6330 Series: Bypass Filters

A & B Connections	316 Stainless Steel
1/4" NPT female	633xF4Y
1/8" GYROLOK®	633xG2Y
1/4" GYROLOK®	633xG4Y

316 Stainless Steel Elements

Micron Range	For 1/8" & 1/4" Size Housings	For 3/8" & 1/2" Size Housings	Identifying Digit	Cv Factor
2 to 5μ	80410-1 80409-1*	—	-1	0.006
5 to 9μ	80410-2 80409-2*	—	-2	0.055
10 to 15μ	80410-3 80409-3*	91442-1	-3	0.33
20 to 30μ	80410-4 80409-4*	—	-4	0.39
40 to 55μ	80410-5 80409-5*	—	-5	0.42
0.5μ	80410-6	—	-6	—
100μ	80410-7	—	-7	—

GYROLOK® is a registered trademark of HOKE®.

* For use with 6330 Series Bypass-type housing



6800 Series

Gauge Valves



Features

- Corrosion-resistant bar stock 316 stainless steel bodies
- Packing below stem threads prevents contamination and wash away of thread lubricants to assure long valve life
- Hardened 17-4 PH 2-piece, non-rotating stem point minimizes seat galling and provides an excellent metal-to-metal seat for positive shutoff
- Low profile bonnet assembly and large diameter stem reduces damage to bonnet and stem assembly
- Roll pin locks bonnet in the valve body to prevent accidental removal
- Choice of 5 $\frac{3}{8}$ " long body for standard process use or 7 $\frac{3}{8}$ " body for insulated piping applications
- Three outlets meet individual gauge requirements
- Polyethylene cap protects stem and bonnet from external damage
- Rugged large handle provides easy grip and control
- All models are stamped with maximum operating pressures on valve body
- High temperature packing is available on special order
- Special High Tolerance NPT Thread

Technical Data

Body Material	316 stainless steel
Maximum Operating Pressure	• 6000 psig @ -65° to +200° F (414 bar @ -54° C to +93° C) • 3000 psig @ +450° F (207 bar @ +232° C)
Operating Temperature Range	-65° F to +450° F (-54° C to +232° C)
Orifice Sizes	6801L8Y: 0.156" (3.96mm) All others: 0.187" (4.75mm)

fluid control

6800 Series

Materials of Construction

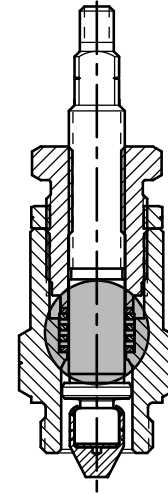
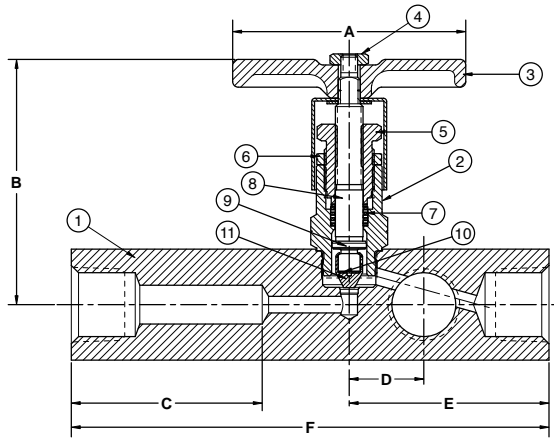

Dyna-Pak® Packing

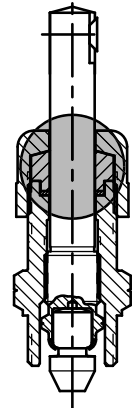

TFE Packing
(6801L8Y only)

Part	316 Stainless Steel Models	
1	Body	316 stainless steel
2	Housing	316 stainless steel
3	Handle	303 stainless steel
4	Hex nut	18-8 stainless steel
5	Packing nut	XM-28 stainless steel
6	Lock nut	316 stainless steel
7	Packing*	Dyna-Pak®
8	Stem	316 stainless steel
9	Washer	316 stainless steel
10	Disc	17-7 PH stainless steel
11	Stem point	17-4 PH stainless steel

Dimensions

Model Number	A	B	C	D	E	F
6801L8Y	inch	1 1/4	2 1/2	1	9/16	1 3/4
	mm	32	64	25	14	44
6802L8Y	inch	2 5/8	3	2 5/8	2 7/8	2 1/4
	mm	67	75	55	21	57
6803L128Y	inch	2 5/8	3	2 5/8	2 7/8	2 1/4
	mm	67	75	55	21	57
6805L128Y	inch	2 5/8	3	4 5/8	2 7/8	2 1/4
	mm	67	75	106	21	57

* Model 6801L8Y uses a single-piece molded PTFE packing system.

Pressure vs. Temperature

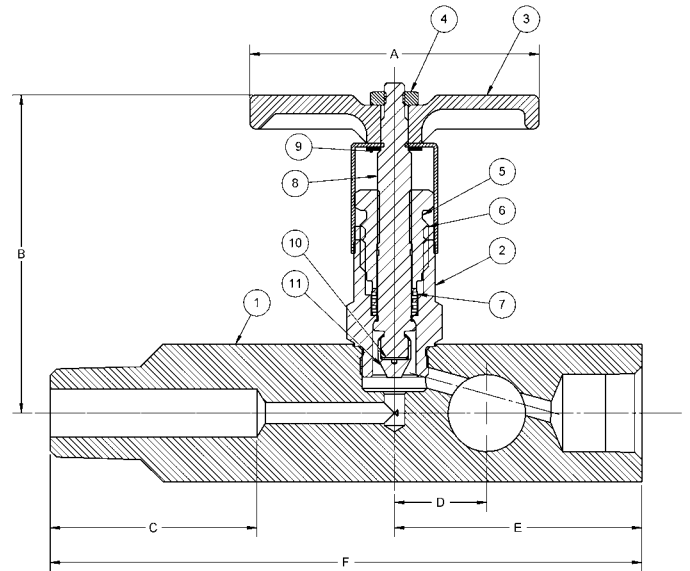
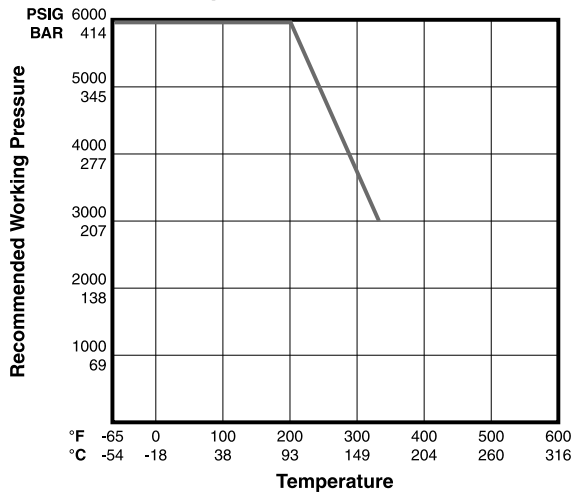

How to Order: Standard Valves

Connections		Order by Part Number 316 Stainless Steel	Body Length	
Inlet	Outlet		Inch	mm
1/2" NPT male	1/2" NPT female	6801L8Y*	3/4	83
1/2" NPT male	1/2" NPT female (3x)	6802L8Y	5/8	136
1/2" NPT female	1/2" NPT female (3x)	6802F8Y	5/8	136
3/4" NPT male	1/2" NPT female (3x)	6803L128Y	5/8	136
3/4" NPT male	1/2" NPT female (3x)	6805L128Y	7/8	188

* Furnished with bleed plug drilled in body
Model 6801L8Y uses a single-piece molded PTFE packing system

Dyna-Pak® is a registered trademark of HOKE®.

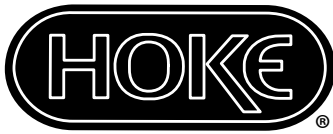

The Small Bore Instrumentation Specialists



We specialize in small bore instrumentation products up to 2" that deliver benchmark performance quality & safety; provide the broadest array of superior alloy offerings in the market; decades of proven success in a wide range of industries; a roster of "who's who" customers & projects globally; original "Best Solution" engineering & designs; and are focused on continuous improvement in all aspects of our business.

Proudly Distributed By:



CRANE INSTRUMENTATION &
SAMPLING Inc.
405 Centura Ct.
Spartanburg, SC 29305, USA
Tel: 1-864-574-7966
PO Box 4866, Spartanburg, SC
29305-4866 USA

Crane Co., and its subsidiaries cannot accept responsibility for possible errors in catalogues, brochures, other printed materials, and website information. Crane Co. reserves the right to alter its products without notice, including products already on order provided that such alteration can be made without changes being necessary in specifications already agreed. All trademarks in this material are the property of the Crane Co. or its subsidiaries. The Crane and Crane brands logotype (CENTER LINE®, COMPAC-NOZ®, CRANE®, DEPA® & ELRO®, DOPAK®, DUO-CHEK®, FLOWSEAL®, GYROLOK®, GO REGULATOR®, HOKE®, JENKINS®, KROMBACH®, NOZ-CHEK®, PACIFIC VALVES®, RESISTOFLEX®, REVO®, SAUNDERS®, STOCKHAM®, TEXAS SAMPLING®, TRIANGLE®, UNI-CHEK®, VALVES®, WTA®, and XOMOX®) are registered trademarks of Crane Co. All rights reserved.