

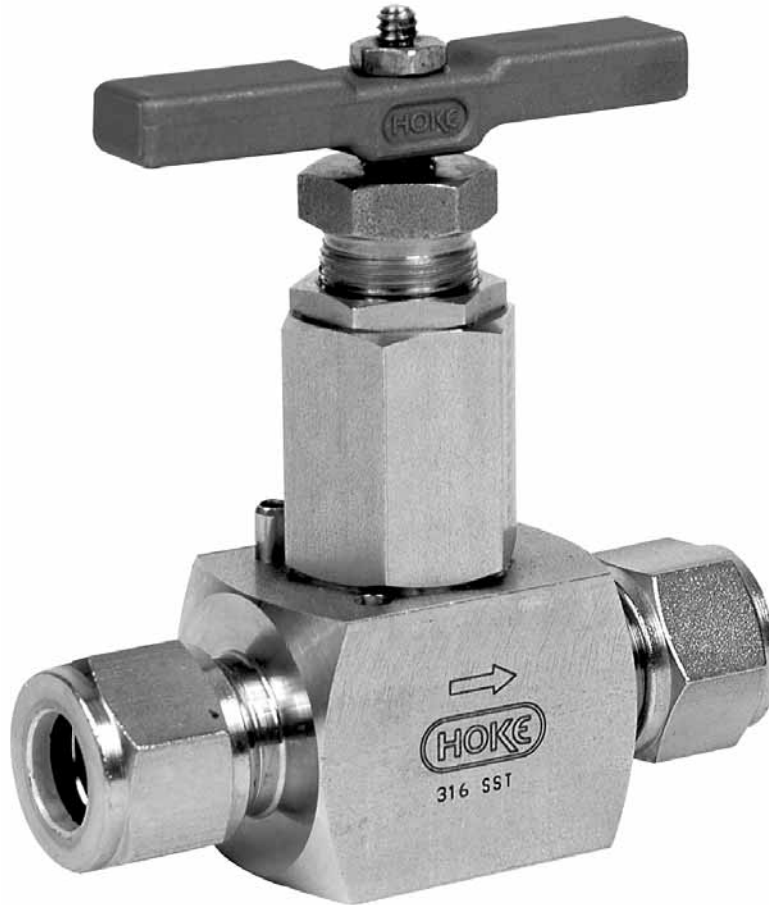

2219 Series

Severe Service Needle Valves



needle valves



CRANE Instrumentation & Sampling, HOKE®
PO Box 4866 • Spartanburg, SC 29305-4866
(864) 574-7966 • www.hoke.com

For Your Safety

It is solely the responsibility of the system designer and user to select products suitable for their specific application requirements and to ensure proper installation, operation, and maintenance of these products. When selecting products, the total system design must be considered to ensure safe, trouble-free performance. Material compatibility, product ratings and application details should be considered in the selection. Improper selection or use of products described herein can cause personal injury or property damage.

Contact your authorized HOKE® sales and service representative for information about additional sizes and special alloys.

SAFETY WARNING:

HOKE® products are designed for installation only by professional suitably qualified licensed system installers experienced in the applications and environments for which the products are intended. These products are intended for integration into a system. Where these products are to be used with flammable or hazardous media, precautions must be taken by the system designer and installer to ensure the safety of persons and property. Flammable or hazardous media pose risks associated with fire or explosion, as well as burning, poisoning or other injury or death to persons and/or destruction of property. The system designer and installer must provide for the capture and control of such substances from any vents in the product(s). The system installer must not permit any leakage or uncontrolled escape of hazardous or flammable substances. The system operator must be trained to follow appropriate precautions and must inspect and maintain the system and its components including the product(s) and at regular intervals in accordance with timescales recommended by the supplier to prevent unacceptable wear or failure.



2219 Series

Severe Service Needle Valves

The HOKE® 2219 Needle Valve is an excellent choice for many steam- and severe service applications. GRAFOIL® packing below the stem threads provides exceptional service at temperatures up to +1000° F (+538° C). The non-rotating 316 stainless steel stem tip prevents galling.



Typical Applications

- Steam service in power plants
- Hot condensates

Technical Data

BODY MATERIAL	316 stainless steel, carbon steel, HASTELLOY® C-276 and MONEL®
MAXIMUM OPERATING PRESSURE	6000 psig @ 70° F (414 bar @ 21° C)
PROOF PRESSURE SAFETY FACTOR	2:1
BURST PRESSURE	4:1
TEMPERATURE RANGE	-100° F to + 1000° F @ 1750 psig max. -75° C to + 538° C @ 120 bar max.
ORIFICE SIZES	0.170", 0.250", 0.312", and 0.437" (4.3 mm, 6.4 mm, 7.9 mm, and 11.1 mm)
C_v FACTORS*	0.47, 1.09, and 1.20

* C_v factor for 0.437" orifice not available at time of publication

Features & Benefits

- Meets ANSI 900# specifications
- GRAFOIL® packing below threads isolates threads from media.
- Non-rotating stem tip prevents galling
- High pressure / high temperature use
- All standard components are 316 stainless steel
- Standard 316 stainless steel cast handle
- Fractional end connections available up to 1"; metric end connections up to 25mm
- GYROLOK®, female NPT, pipe, or tube socket weld end connections
- Bubble-tight leak testing at both seat and packing
- Special High Tolerance NPT Thread

needle valves

2219 Series Severe Service Needle Valve

Dimensions

INLET A	OUTLET B	ORIFICE SIZE	C		D	E	F
			inch	mm	inch	mm	inch
¼" female NPT	¼" female NPT	0.250" (6.4 mm)	inch	3.4	2.63	2.25	N/A
			mm	86.4	66.8	57.2	N/A
½" female NPT	½" female NPT	0.312" (7.9 mm)	inch	3.4	2.63	2.51	N/A
			mm	86.4	66.8	63.8	N/A
¾" female NPT	¾" female NPT	0.437" (11.1 mm)	inch	3.55	2.63	3.50	N/A
			mm	89.6	66.8	88.9	N/A
1" female NPT	1" female NPT	0.437" (11.1 mm)	inch	3.59	2.63	4.25	N/A
			mm	91.3	66.8	108.0	N/A
¼" GYROLOK®	¼" GYROLOK®	0.170" (4.3 mm)	inch	3.4	2.63	1.87	3.15
			mm	86.4	66.8	47.4	80.1
½" GYROLOK®	½" GYROLOK®	0.250" (6.4 mm)	inch	3.4	2.63	1.50	3.43
			mm	86.4	66.8	38.1	87.1
¾" GYROLOK®	¾" GYROLOK®	0.437" (11.1 mm)	inch	3.53	2.63	2.88	4.87
			mm	89.7	66.8	73.2	123.8
1" GYROLOK®	1" GYROLOK®	0.437" (11.1 mm)	inch	3.53	2.63	2.51	5.00
			mm	89.7	66.8	63.8	120.9
12 mm GYROLOK®	12 mm GYROLOK®	0.250" (6.4 mm)	inch	3.40	2.63	1.51	3.36
			mm	86.4	66.8	38.5	85.4
22 mm GYROLOK®	22 mm GYROLOK®	0.437" (11.1 mm)	inch	3.53	2.63	2.76	4.86
			mm	89.7	66.8	70.1	123.3
25 mm GYROLOK®	25 mm GYROLOK®	0.437" (11.1 mm)	inch	3.53	2.63	2.51	5.11
			mm	89.7	66.8	63.8	129.7
⅜" tube socket weld	⅜" tube socket weld	0.250" (6.4 mm)	inch	3.4	2.63	1.94	2.44
			mm	86.4	66.8	49.3	62.0
½" tube socket weld	½" tube socket weld	0.250" (6.4 mm)	inch	3.40	2.63	1.94	2.44
			mm	86.4	66.8	49.3	62.0
¾" tube socket weld	¾" tube socket weld	0.437" (11.1 mm)	inch	3.53	2.63	2.50	3.50
			mm	89.7	66.8	63.5	88.9
1" tube socket weld	1" tube socket weld	0.437" (11.1 mm)	inch	3.53	2.63	2.50	3.50
			mm	89.7	66.8	63.5	88.9
⅜" NPS socket weld	⅜" NPS socket weld	0.250" (6.4 mm)	inch	3.4	2.63	2.01	2.51
			mm	56.4	66.8	51.05	63.8
½" NPS socket weld	½" NPS socket weld	0.312" (7.9 mm)	inch	3.4	2.63	1.75	2.51
			mm	86.4	66.8	44.45	63.8
¾" NPS socket weld	¾" NPS socket weld	0.437" (11.1 mm)	inch	3.53	2.63	2.50	3.50
			mm	89.7	66.8	63.5	88.9
1" NPS socket weld	1" NPS socket weld	0.437" (11.1 mm)	inch	3.59	2.63	2.50	3.50
			mm	91.3	66.8	63.5	88.9

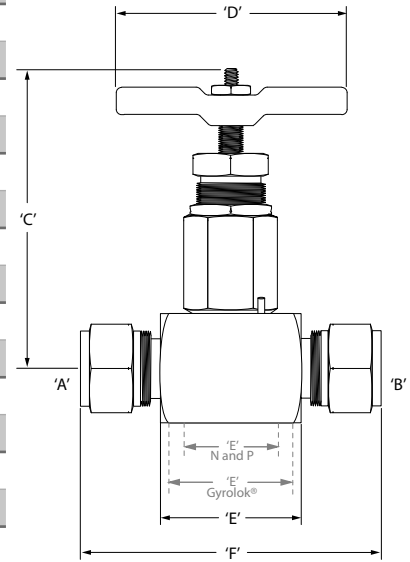

Dimensions for reference only, subject to change.

Materials of Construction*

DESCRIPTION	MATERIAL
1 Handle	316 stainless steel
2 Stem assembly	316 stainless steel
3 Packing nut	316 stainless steel
4 Body	316 stainless steel
5 Packing	GRAFOIL®
6 Packing washer	316 stainless steel

* This listing contains standard valve information only. See page 4 for a complete list of options.

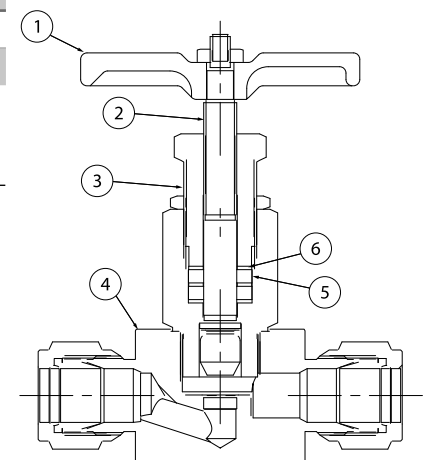

2219 Series Severe Service Needle Valve

Pressure vs. Temperature Curve

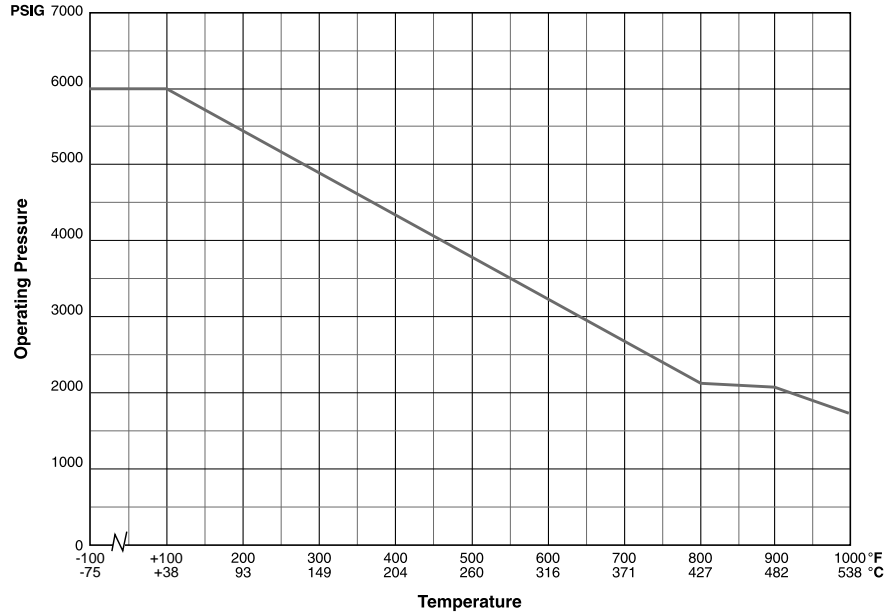

Flow Curve

Handle Turns vs. C_v

2219 SERIES FLOW CURVES

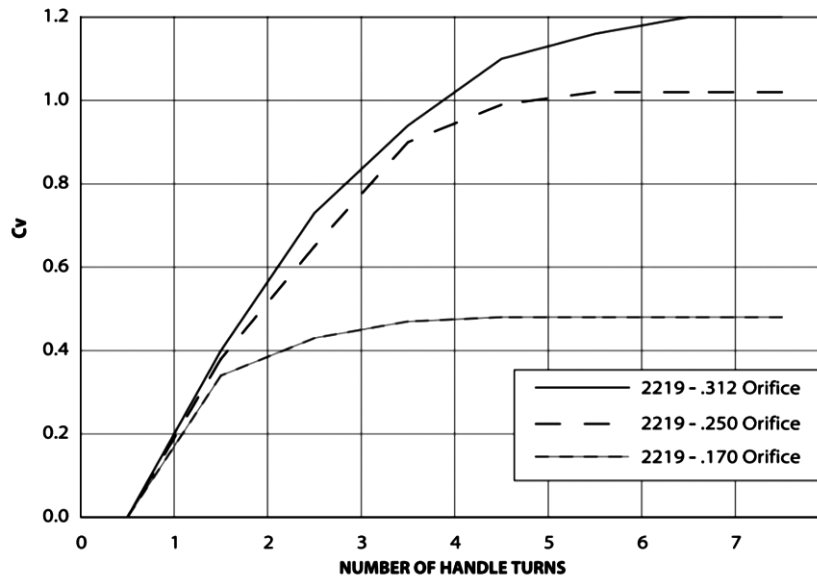

2219 .437 ORIFICE FLOW CURVE

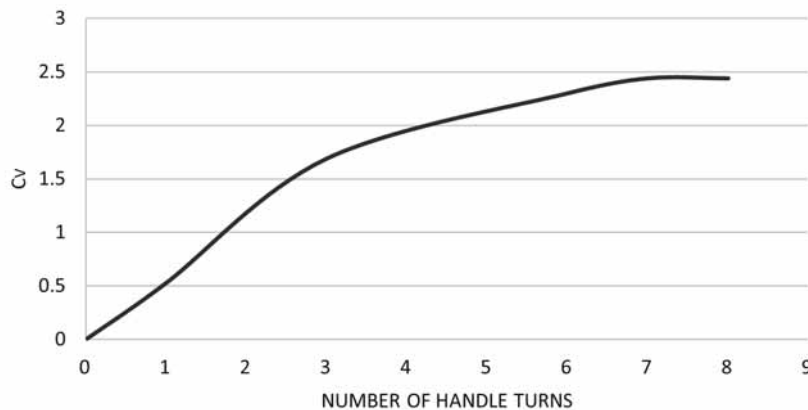

2219 Series Severe Service Needle Valve

How to Order: Build-to-Order

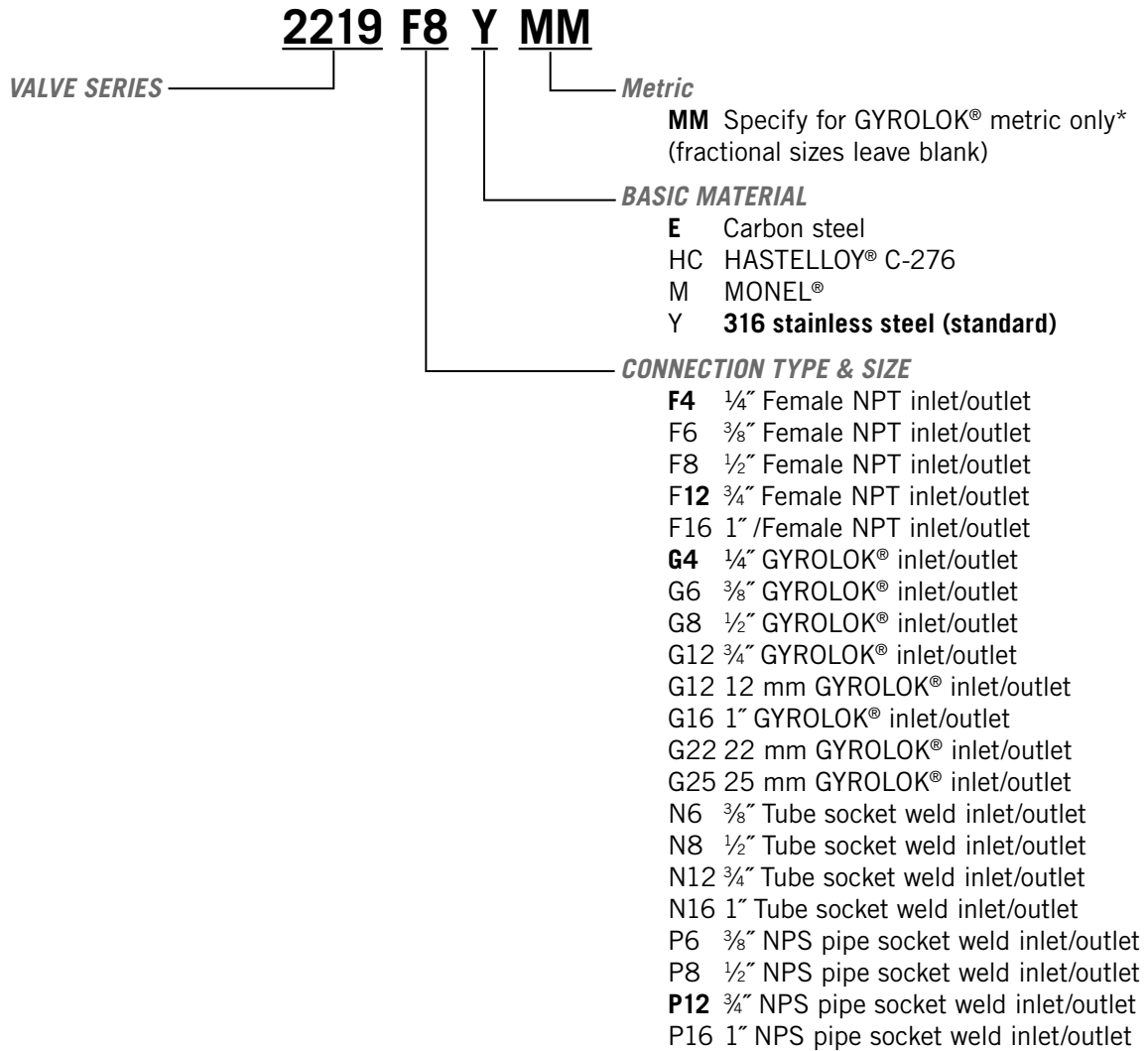

* Consult factory for metric connections and additional material options.

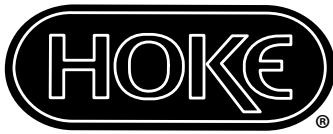

The Small Bore Instrumentation Specialists



We specialize in small bore instrumentation products up to 2" that deliver benchmark performance quality & safety; provide the broadest array of superior alloy offerings in the market; decades of proven success in a wide range of industries; a roster of "who's who" customers & projects globally; original "Best Solution" engineering & designs; and are focused on continuous improvement in all aspects of our business.

Proudly Distributed By:



CRANE INSTRUMENTATION &
SAMPLING Inc.
405 Centura Ct.
Spartanburg, SC 29305, USA
Tel: 1-864-574-7966
PO Box 4866, Spartanburg, SC
29305-4866 USA

Crane Co., and its subsidiaries cannot accept responsibility for possible errors in catalogues, brochures, other printed materials, and website information. Crane Co. reserves the right to alter its products without notice, including products already on order provided that such alteration can be made without changes being necessary in specifications already agreed. All trademarks in this material are the property of the Crane Co. or its subsidiaries. The Crane and Crane brands logotype (CENTER LINE®, COMPAC-NOZ®, CRANE®, DEPA® & ELRO®, DOPAK®, DUO-CHEK®, FLOWSEAL®, GYROLOK®, GO REGULATOR®, HOKE®, JENKINS®, KROMBACH®, NOZ-CHEK®, PACIFIC VALVES®, RESISTOFLEX®, REVO®, SAUNDERS®, STOCKHAM®, TEXAS SAMPLING®, TRIANGLE®, UNI-CHEK®, VALVES®, WTA®, and XOMOX®) are registered trademarks of Crane Co. All rights reserved.