

MAXIMUM WORKING CONDITIONS
 COLD WORKING PRESSURE:
 STANDARD, 6,000PSI (414BAR)
 (AT REDUCED TEMPERATURE)

TEMPERATURE:
 -29°C (-20.2°F) TO 200°C (392°F)
 (AT REDUCED PRESSURE)

APPROX WEIGHT
 1.4Kg

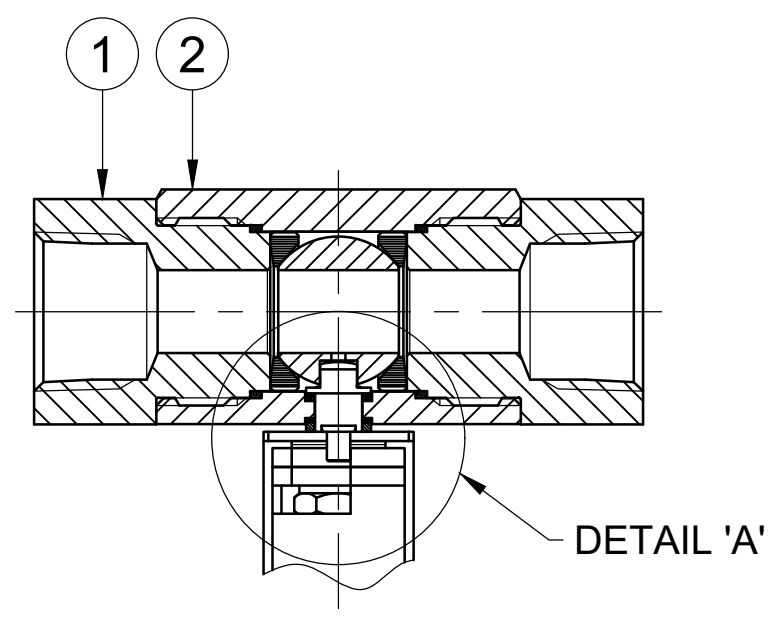
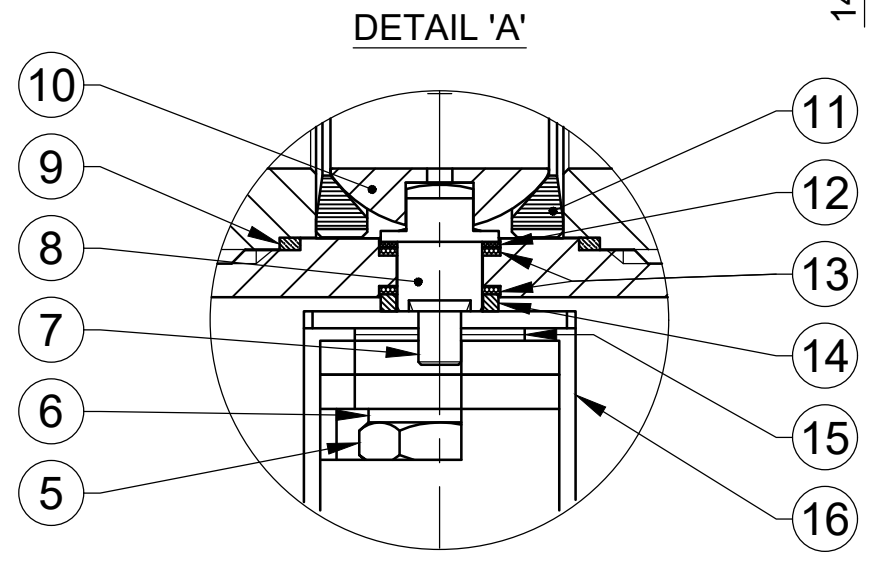
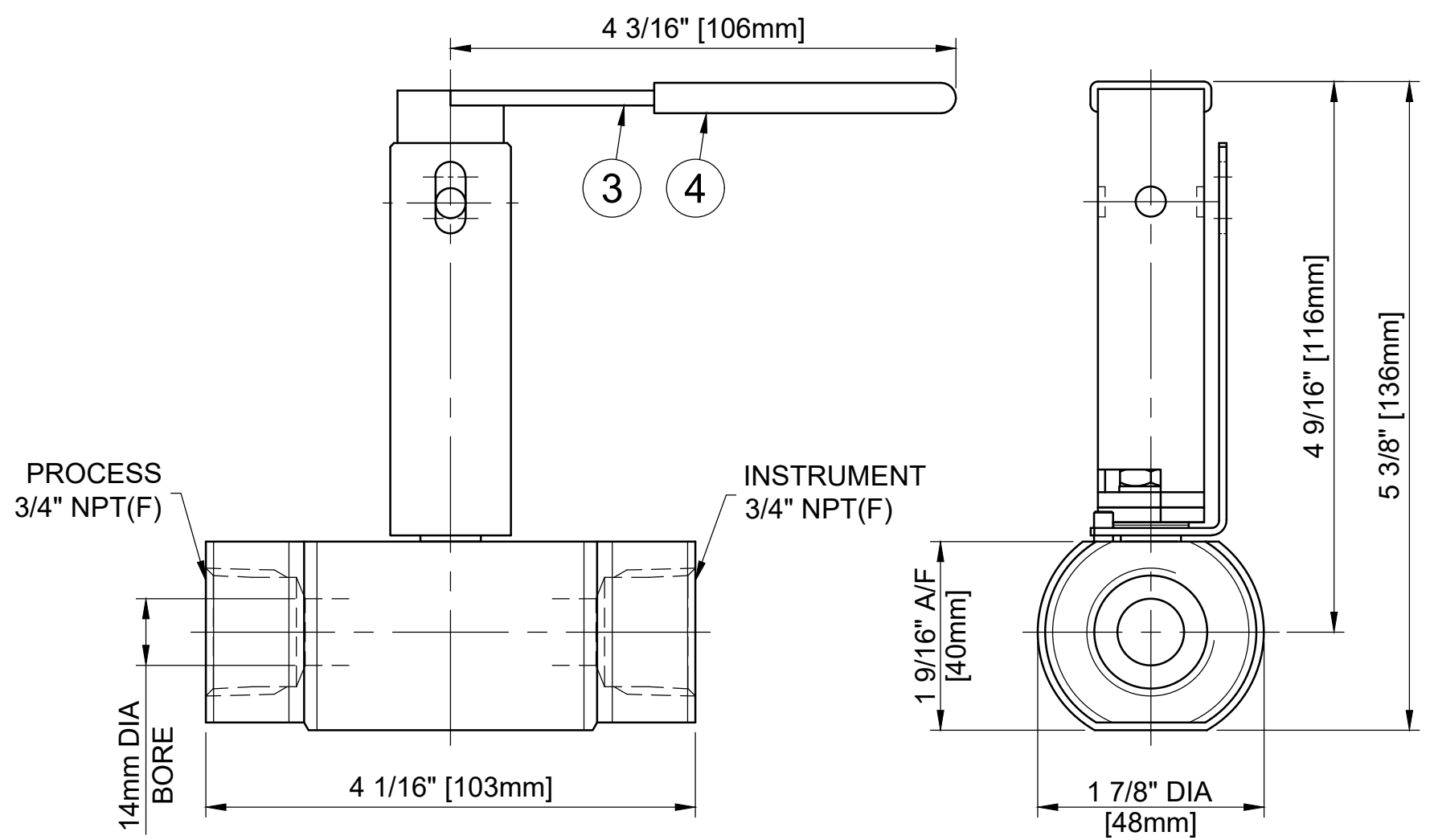

REF No	DESCRIPTION	MATERIAL
		6MO
1	END CONNECTOR	ASTM A276/A479 UNS S31254
2	BODY	ASTM A276/A479 UNS S31254
3	HANDLE	316 SS
4	SLEEVE	PVC
5	NUT	A4 [316] SS
6	SERRATED WASHER	316 SS
7	HANDLE STOP PIN	316 SS
8	SPINDLE	ASTM B446 UNS N06625
9	END CONNECTOR SEAL	100% VIRGIN PTFE
10	BALL	ASTM A276/A479 UNS S31254
11	SEAT	PEEK
12	THRUST SEAL	25% GLASS FILLED PTFE
13	SPINDLE SEALS	15% GLASS FILLED PTFE
14	PISTON RING	316 SS
15	DISC SPRING	316 SS
16	LOCKING PLATE	316 SS

MARKING DETAILS
 (MARKING REFERENCE ONLY)



REMARK

- ADDITIONAL TAG PLATE FOR ADDITIONAL INFO UPON REQUESTED
- HCT HEAT CODE TRACEABILITY WILL BE MARKED ON BODY & END FITTINGS

THE INFORMATION CONTAINED IN THIS DRAWING IS THE PROPERTY OF CRANE COMPANY. ANY REPRODUCTION IN PART OR AS A WHOLE WITHOUT THE WRITTEN PERMISSION OF CRANE COMPANY IS PROHIBITED.

REMOVE ALL BURRS, DO NOT SCALE DRAWING, DRILL POINTS STD

BREAK CORNERS 0.005 - 0.010

UNLESS OTHERWISE SPECIFIED, DIMENSIONS ARE IN INCHES

TOLERANCES ARE:
 .XXX +.005 ANGLES ±.41°
 .XX +.010 CONCENTRICITY ±0.015
 .X +.060 MACHINE FINISH: 63RMS

APPROVALS		DATE
CREATED	ZL	16/01/24
DRAWN	ZL	16/01/24
APPROVED	GT	17/01/24

EC NUMBER X

INITIAL USAGE (REF ONLY) X

CAD FILE NAME

CRANE	HOKE
-------	------

SPARTANBURG, SOUTH CAROLINA 29303

TITLE: GENERAL ARRANGEMENT - 14mm BORE SINGLE ISOLATE BALL VALVE WITH 3/4" NPT FEMALE CONNECTIONS & EXTENDED HANDLE LOCKING.

SIZE: A3

SCALE: N.T.S

DWG NO: A18806

SHEET 1 OF 1