

MAXIMUM WORKING CONDITIONS
 COLD WORKING PRESSURE:
 STANDARD, 6,000PSI (414BAR)
 (AT REDUCED TEMPERATURE)

TEMPERATURE:
 -29°C (-20.2°F) TO 200°C (392°F)
 (AT REDUCED PRESSURE)

APPROX WEIGHT
 2.1Kg

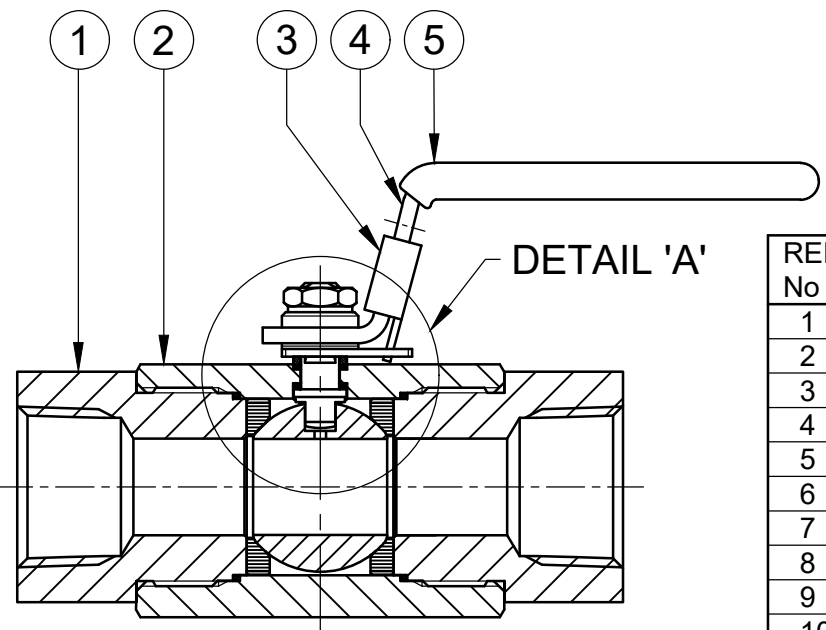
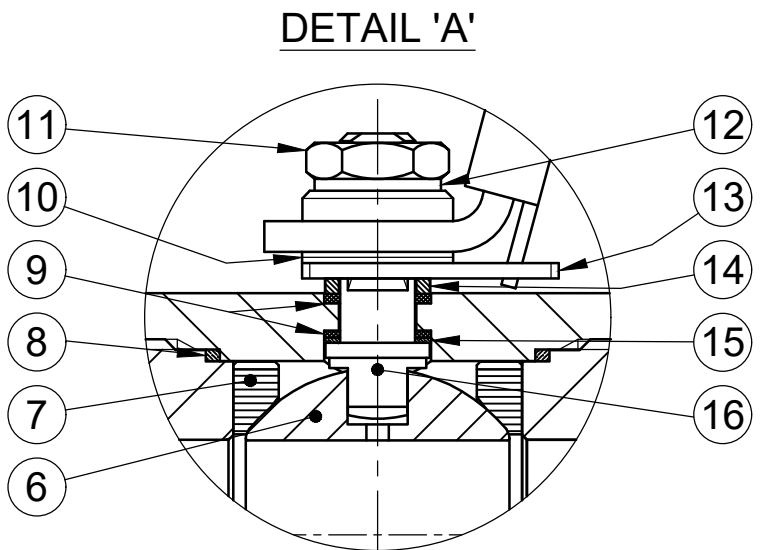
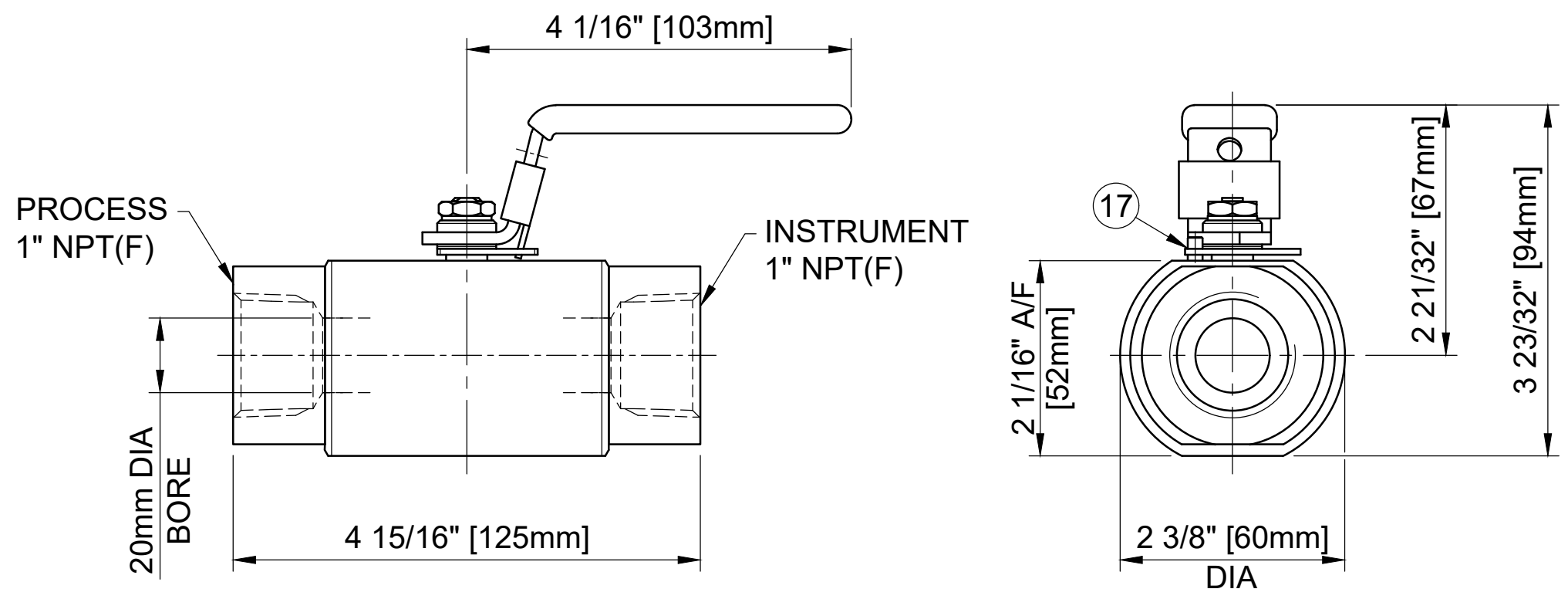

REF No	DESCRIPTION	MATERIAL
		6MO
1	END CONNECTOR	ASTM A276/A479 UNS S31254
2	BODY	ASTM A276/A479 UNS S31254
3	LOCK TAB	316 SS
4	HANDLE	316 SS
5	SLEEVE	PVC
6	BALL	ASTM A276/A479 UNS S31254
7	SEAT	PEEK
8	END CONNECTOR SEAL	100% VIRGIN PTFE
9	SPINDLE SEALS	15% GLASS FILLED PTFE
10	DISC SPRING	316 SS
11	NUT	A4 [316] SS
12	SERRATED WASHER	316 SS
13	LOCKING PLATE	316 SS
14	PISTON RING	316 SS
15	THRUST SEAL	25% GLASS FILLED PTFE
16	SPINDLE	API 6ACRA UNS N07718
17	HANDLE STOP PIN	316 SS

MARKING DETAILS
 (MARKING REFERENCE ONLY)



REMARK

- ADDITIONAL TAG PLATE FOR ADDITIONAL INFO UPON REQUESTED
- HCT HEAT CODE TRACEABILITY WILL BE MARKED ON BODY & END FITTINGS

THE INFORMATION CONTAINED IN THIS DRAWING IS THE PROPERTY OF CRANE COMPANY. ANY REPRODUCTION IN PART OR AS A WHOLE WITHOUT THE WRITTEN PERMISSION OF CRANE COMPANY IS PROHIBITED.

REMOVE ALL BURRS, DO NOT SCALE DRAWING, DRILL POINTS STD

BREAK CORNERS 0.005 - 0.010

UNLESS OTHERWISE SPECIFIED, DIMENSIONS ARE IN INCHES

TOLERANCES ARE:
 .XXX +.005 ANGLE ±.1°
 .XX +.010 CONCENTRICITY ±.015
 X +.060 MACHINE FINISH 63RMS

APPROVALS		DATE
CREATED	JQ	10/10/23
DRAWN	JQ	10/10/23
APPROVED	ZL	11/10/23

EC NUMBER X

INITIAL USAGE (REF ONLY) X

CAD FILE NAME

CRANE	HOKE
-------	------

SPARTANBURG, SOUTH CAROLINA 29303

TITLE GENERAL ARRANGEMENT - 20mm BORE SINGLE ISOLATE BALL VALVE WITH 1" NPT FEMALE CONNECTION & HANDLE LOCKING.

SIZE A3

SCALE N.T.S

DWG NO. A18637

SHEET 1 OF 1