

**MAXIMUM WORKING CONDITIONS**  
 COLD WORKING PRESSURE:  
 STANDARD, 6,000PSI (414BAR)  
 (AT REDUCED TEMPERATURE)

TEMPERATURE:  
 -29°C (-20.2°F) TO 200°C (392°F)  
 (AT REDUCED PRESSURE)

APPROX WEIGHT  
 0.4Kg

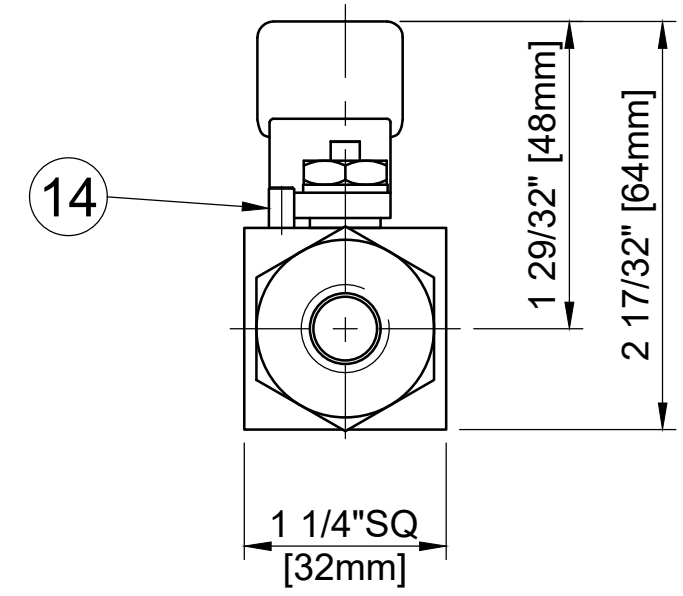
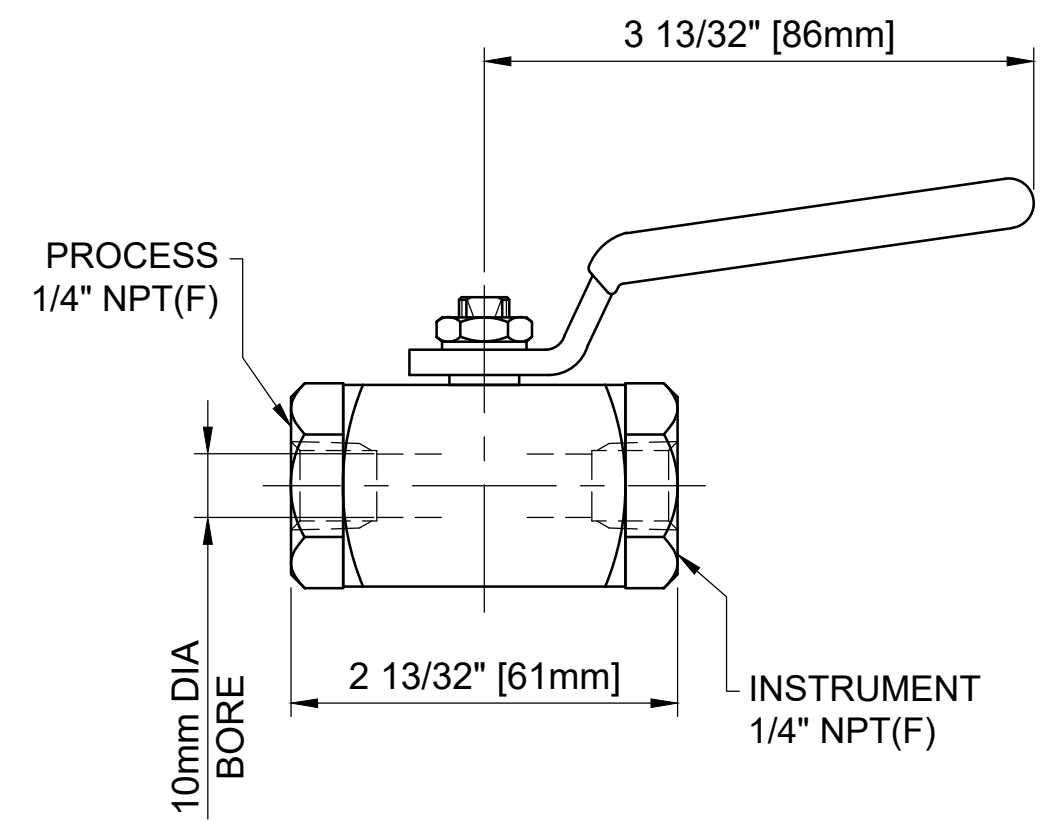

**DETAIL 'A'**

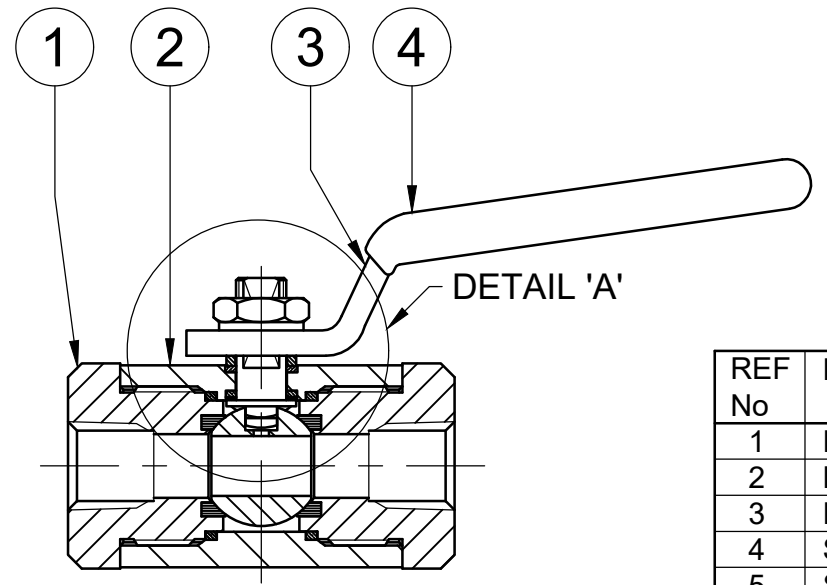
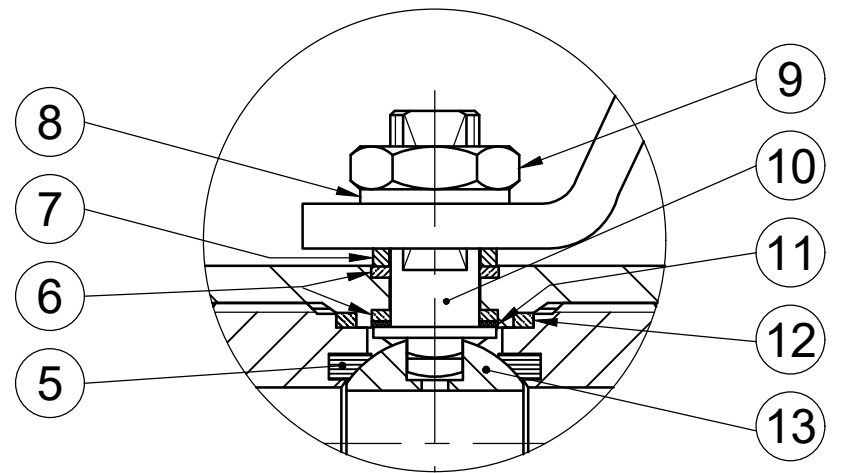

REF No	DESCRIPTION	MATERIAL
		STAINLESS
1	END CONNECTOR	ASTM A276 /A479 316
2	BODY	ASTM A276 /A479 316
3	HANDLE	316 SS
4	SLEEVE	PVC
5	SEAT	MODIFIED PEEK
6	SPINDLE SEALS	15% GLASS FILLED PTFE
7	PISTON RING	316 SS
8	SERRATED WASHER	316 SS
9	NUT	A4 [316] SS
10	SPINDLE	ASTM A276 /A479 316
11	THRUST SEAL	25% GLASS FILLED PTFE
12	BODY SEAL	100% VIRGIN PTFE
13	BALL	ASTM A276 /A479 316
14	STOP PIN	316 SS

**MARKING DETAILS**  
 (MARKING REFERENCE ONLY)



**REMARK**

- ADDITIONAL TAG PLATE FOR ADDITIONAL INFO UPON REQUESTED
- HCT HEAT CODE TRACEABILITY WILL BE MARKED ON BODY & END FITTINGS

THE INFORMATION CONTAINED IN THIS DRAWING IS THE PROPERTY OF CRANE COMPANY. ANY REPRODUCTION IN PART OR AS A WHOLE WITHOUT THE WRITTEN PERMISSION OF CRANE COMPANY IS PROHIBITED.

APPROVALS	DATE	<p>SPARTANBURG, SOUTH CAROLINA 29303</p> <p>TITLE: GENERAL ARRANGEMENT - 10mm BORE SINGLE ISOLATE BALL VALVE WITH 1/4" NPT FEMALE CONNECTIONS.</p>
CREATED ZL	13/10/23	
DRAWN ZL	13/10/23	
APPROVED JQ	17/10/23	
BREAK CORNERS 0.005 - 0.010	UNLESS OTHERWISE SPECIFIED, DIMENSIONS ARE IN INCHES	EC NUMBER X
TOLERANCES ARE:	ANGLES ±.1°	INITIAL USAGE (REF ONLY) X
.XXX ±.005	CENTRICITY ±0.015	CAD FILE NAME
.XX ±.010	MACHINE FINISH: 63RMS	SCALE N.T.S.
.X ±.060		SIZE A3
		SCALE N.T.S.

SIZE A3  
 SCALE N.T.S.  
 DWG NO. A18640  
 SHEET 1 OF 1