

MAXIMUM WORKING CONDITIONS
 COLD WORKING PRESSURE:
 STANDARD, 6,000PSI (414BAR)
 (AT REDUCED TEMPERATURE)

TEMPERATURE:
 -29°C (-20.2°F) TO 200°C (392°F)
 (AT REDUCED PRESSURE)

APPROX WEIGHT
 1.2Kg

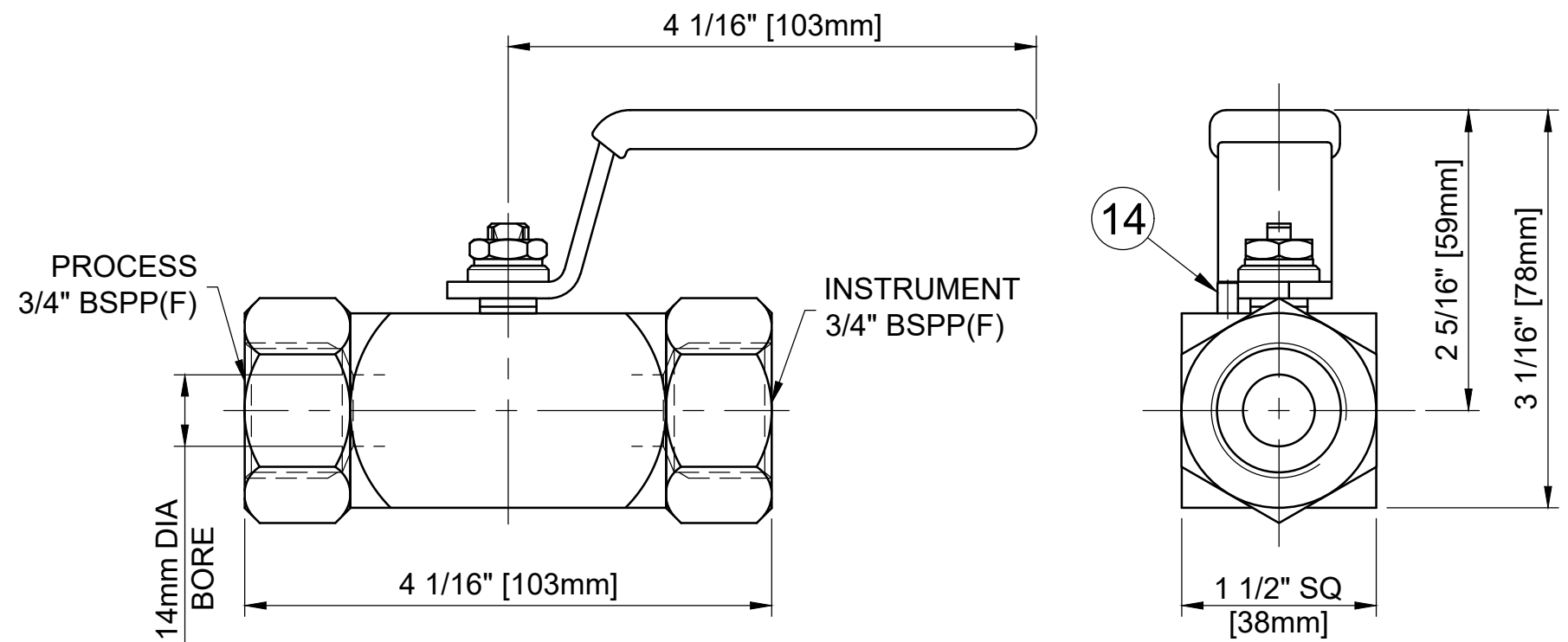

DETAIL 'A'

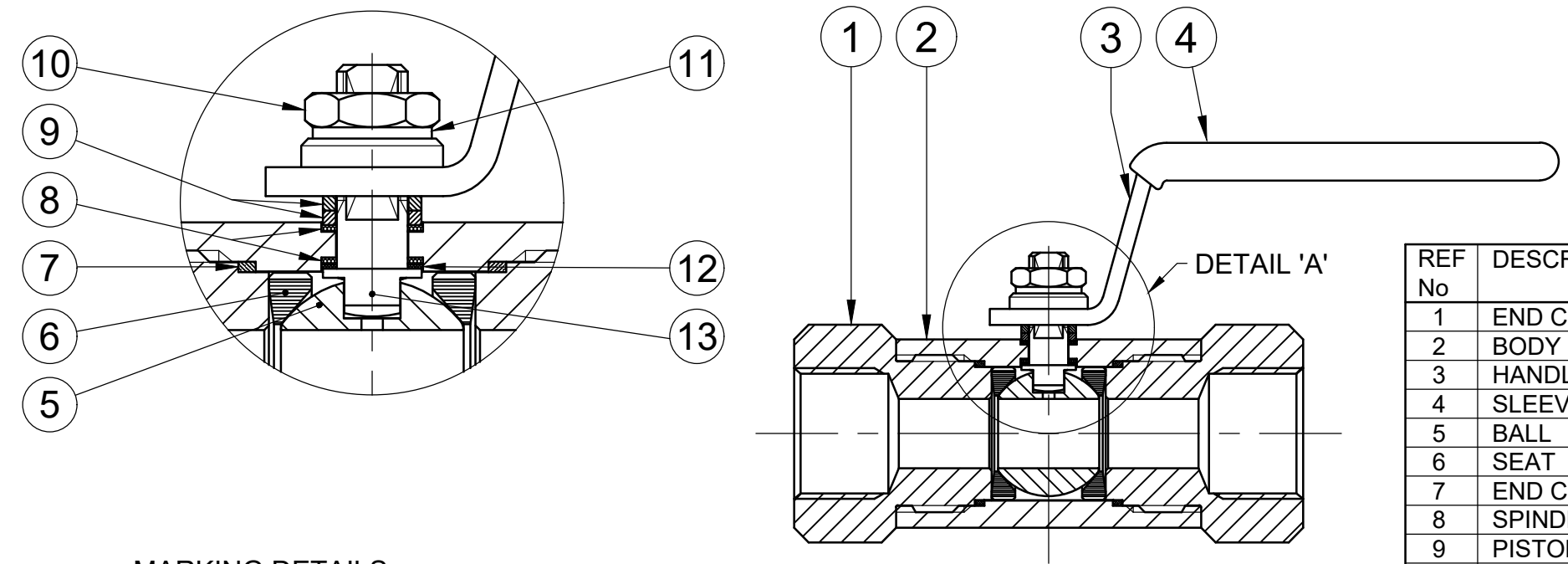

REF No	DESCRIPTION	MATERIAL
		STAINLESS
1	END CONNECTOR	ASTM A276/A479 316
2	BODY	ASTM A276/A479 316
3	HANDLE	316 SS
4	SLEEVE	PVC
5	BALL	ASTM A276/A479 316
6	SEAT	PEEK
7	END CONNECTOR SEAL	100% VIRGIN PTFE
8	SPINDLE SEALS	15% GLASS FILLED PTFE
9	PISTON RING	316 SS
10	NUT	A4 [316] SS
11	SERRATED WASHER	316 SS
12	THRUST SEAL	25% GLASS FILLED PTFE
13	SPINDLE	ASTM A276/A479 UNS S31803
14	HANDLE STOP PIN	316 SS

MARKING DETAILS
 (MARKING REFERENCE ONLY)



REMARK

- ADDITIONAL TAG PLATE FOR ADDITIONAL INFO UPON REQUESTED
- HCT HEAT CODE TRACEABILITY WILL BE MARKED ON BODY & END FITTINGS

THE INFORMATION CONTAINED IN THIS DRAWING IS THE PROPERTY OF CRANE COMPANY. ANY REPRODUCTION IN PART OR AS A WHOLE WITHOUT THE WRITTEN PERMISSION OF CRANE COMPANY IS PROHIBITED.

APPROVALS	DATE	<p>SPARTANBURG, SOUTH CAROLINA 29303</p> <p>TITLE: GENERAL ARRANGEMENT - 14mm BORE SINGLE ISOLATE BALL VALVE WITH 3/4" BSPP FEMALE CONNECTIONS.</p>
CREATED ZL	17/10/23	
DRAWN ZL	17/10/23	
APPROVED JQ	18/10/23	
BREAK CORNERS 0.005 - 0.010	UNLESS OTHERWISE SPECIFIED, DIMENSIONS ARE IN INCHES	EC NUMBER X
TOLERANCES ARE:	ANGLES ±.41°	INITIAL USAGE (REF ONLY) X
.XXX ±.005	CENTRICITY ±.0015	CAD FILE NAME
.XX ±.010	MACHINE FINISH: 63RMS	SCALE N.T.S
.X ±.060		SIZE A3
		SCALE N.T.S

SIZE A3
 SCALE N.T.S
 DWG NO. A18659
 SHEET 1 OF 1