

MAXIMUM WORKING CONDITIONS
 COLD WORKING PRESSURE:
 STANDARD, 6,000PSI (414BAR)
 (AT REDUCED TEMPERATURE)

TEMPERATURE:
 -29°C (-20.2°F) TO 200°C (392°F)
 (AT REDUCED PRESSURE)

APPROX WEIGHT
 1.9Kg

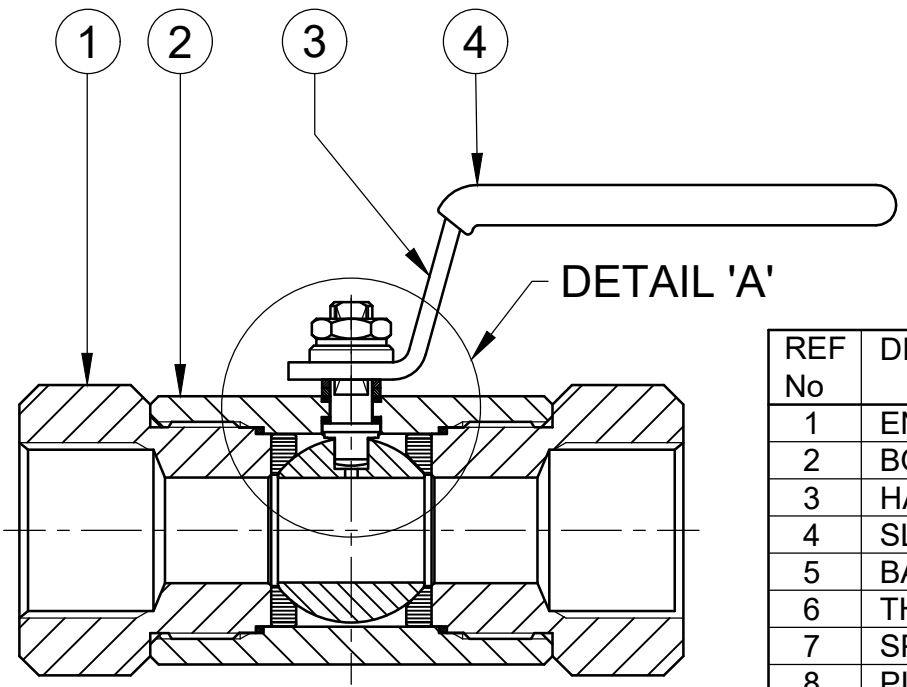
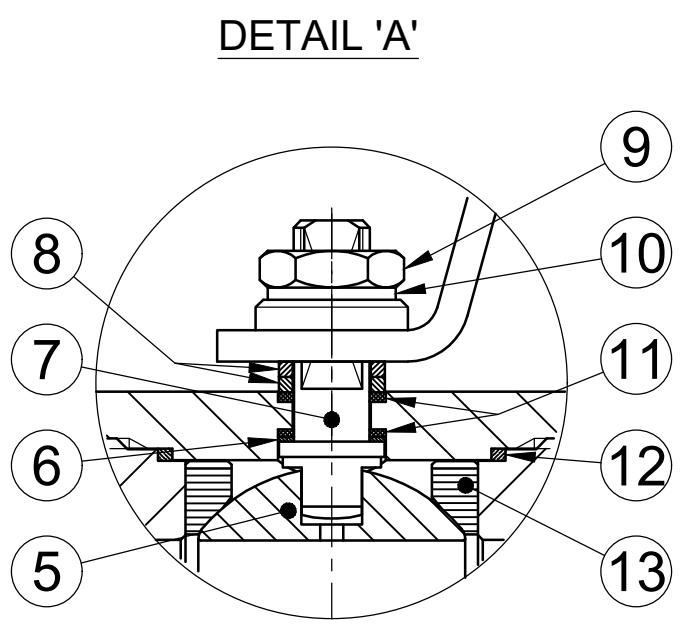
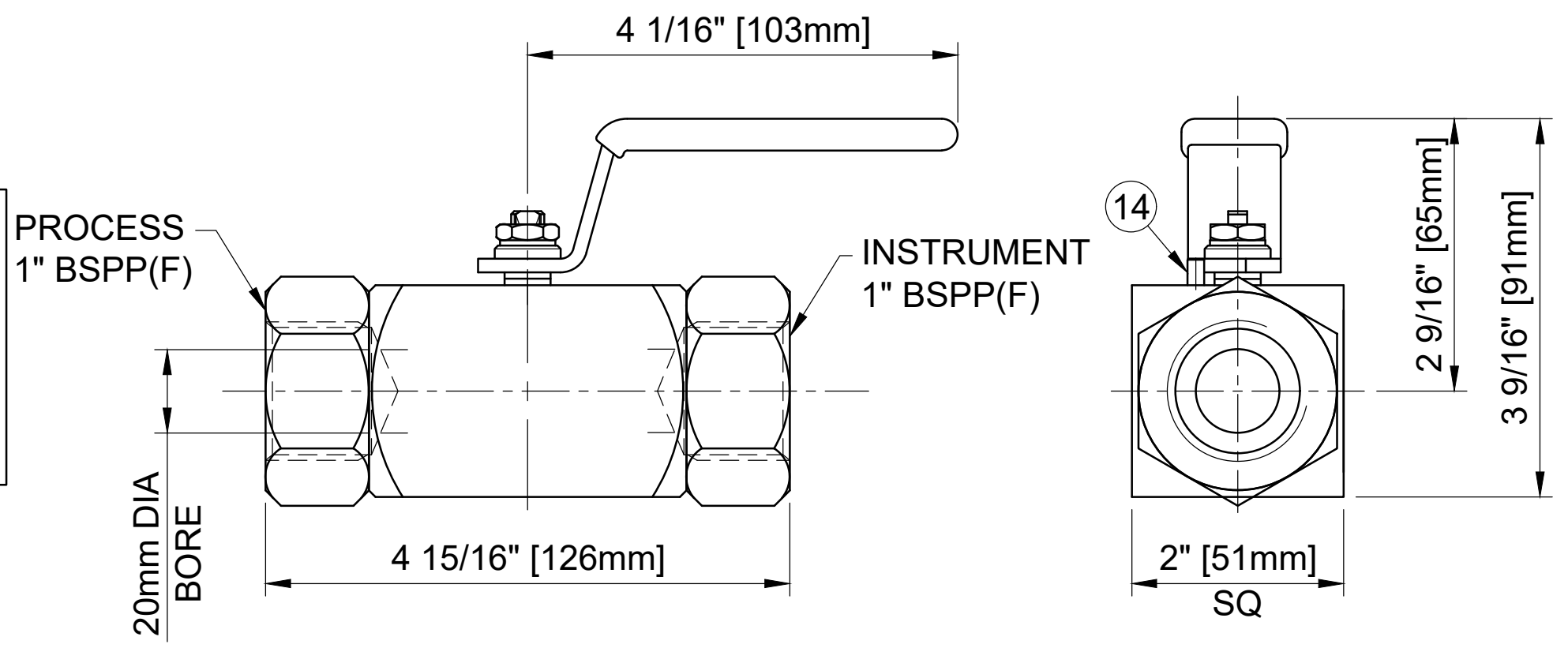

REF No	DESCRIPTION	MATERIAL
		STAINLESS
1	END CONNECTOR	ASTM A276 /A479 316
2	BODY	ASTM A276 /A479 316
3	HANDLE	316 SS
4	SLEEVE	PVC
5	BALL	ASTM A276 /A479 316
6	THRUST SEAL	25% GLASS FILLED PTFE
7	SPINDLE	ASTM A276 /A479 UNS S32760
8	PISTON RING	316 SS
9	NUT	A4 [316] SS
10	SERRATED WASHER	316 SS
11	SPINDLE SEALS	15% GLASS FILLED PTFE
12	BODY SEAL	100% VIRGIN PTFE
13	SEAT	PEEK
14	HANDLE STOP PIN	316 SS

MARKING DETAILS
 (MARKING REFERENCE ONLY)



REMARK

- ADDITIONAL TAG PLATE FOR ADDITIONAL INFO UPON REQUESTED
- HCT HEAT CODE TRACEABILITY WILL BE MARKED ON BODY & END FITTINGS

THE INFORMATION CONTAINED IN THIS DRAWING IS THE PROPERTY OF CRANE COMPANY. ANY REPRODUCTION IN PART OR AS A WHOLE WITHOUT THE WRITTEN PERMISSION OF CRANE COMPANY IS PROHIBITED.

REMOVE ALL BURRS, DO NOT SCALE DRAWING, DRILL POINTS STD

BREAK CORNERS 0.005 - 0.010

UNLESS OTHERWISE SPECIFIED, DIMENSIONS ARE IN INCHES

TOLERANCES ARE:
 .XXX +.005 ANGLES ±.41°
 .XX +.010 CONCENTRICITY ±.0015
 .X +.060 MACHINE FINISH: 63RMS

APPROVALS		DATE
CREATED	JQ	18/10/23
DRAWN	JQ	18/10/23
APPROVED	ZL	19/10/23

EC NUMBER X

INITIAL USAGE (REF ONLY) X

CAD FILE NAME

APPROVALS: CRANE, HOKE

SPARTANBURG, SOUTH CAROLINA 29303

TITLE: GENERAL ARRANGEMENT - 20mm BORE SINGLE ISOLATE BALL VALVE WITH 1" BSPP FEMALE CONNECTIONS.

SIZE: A3

SCALE: N.T.S

DWG NO: A18655

SHEET 1 OF 1