

MAXIMUM WORKING CONDITIONS
 COLD WORKING PRESSURE:
 STANDARD, 6,000PSI (414BAR)
 (AT REDUCED TEMPERATURE)

TEMPERATURE:
 -29°C (-20.2°F) TO 200°C (392°F)
 (AT REDUCED PRESSURE)

APPROX WEIGHT
 0.5Kg

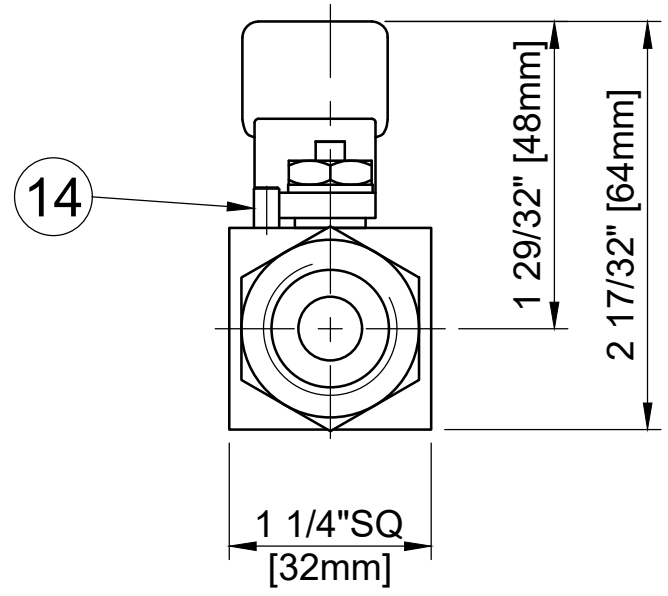
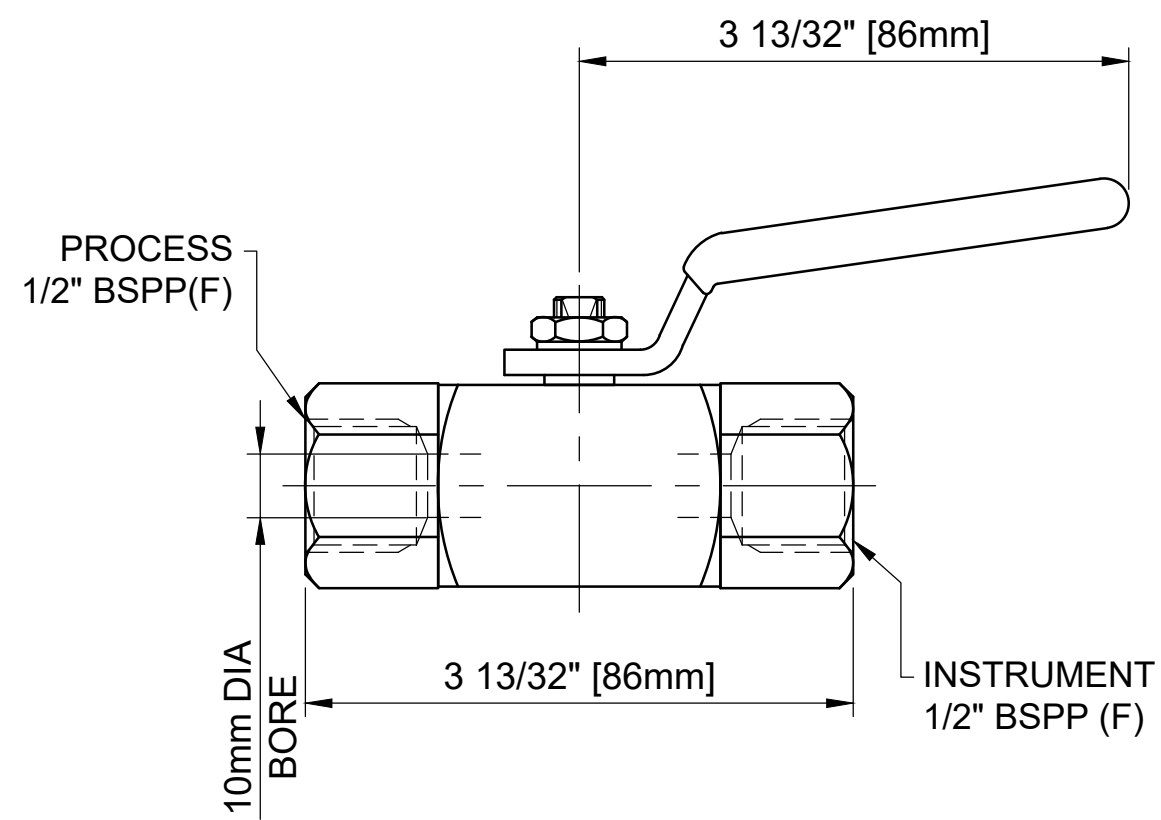

DETAIL 'A'

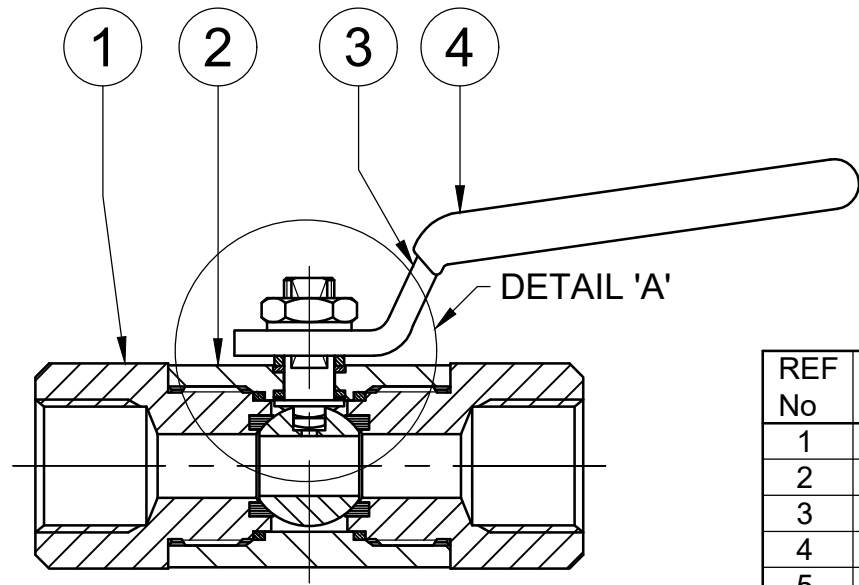
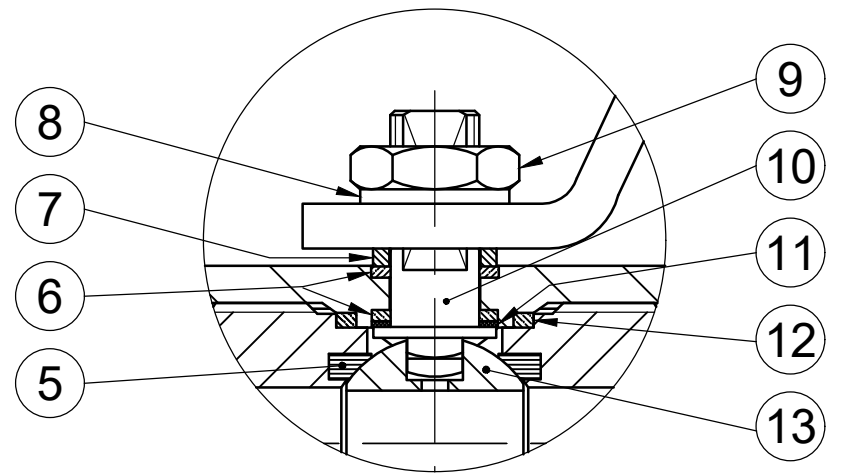

REF No	DESCRIPTION	MATERIAL
		STAINLESS
1	END CONNECTOR	ASTM A276 /A479 316
2	BODY	ASTM A276 /A479 316
3	HANDLE	316 SS
4	SLEEVE	PVC
5	SEAT	MODIFIED PEEK
6	SPINDLE SEALS	15% GLASS FILLED PTFE
7	PISTON RING	316 SS
8	SERRATED WASHER	316 SS
9	NUT	A4 [316] SS
10	SPINDLE	ASTM A276 /A479 316
11	THRUST SEAL	25% GLASS FILLED PTFE
12	BODY SEAL	100% VIRGIN PTFE
13	BALL	ASTM A276 /A479 316
14	STOP PIN	316 SS

MARKING DETAILS
 (MARKING REFERENCE ONLY)



REMARK

- ADDITIONAL TAG PLATE FOR ADDITIONAL INFO UPON REQUESTED
- HCT HEAT CODE TRACEABILITY WILL BE MARKED ON BODY & END FITTINGS

THE INFORMATION CONTAINED IN THIS DRAWING IS THE PROPERTY OF CRANE COMPANY. ANY REPRODUCTION IN PART OR AS A WHOLE WITHOUT THE WRITTEN PERMISSION OF CRANE COMPANY IS PROHIBITED.

APPROVALS	DATE	
CREATED ZL	13/10/23	
DRAWN ZL	13/10/23	SPARTANBURG, SOUTH CAROLINA 29303 TITLE GENERAL ARRANGEMENT - 10mm BORE SINGLE ISOLATE BALL VALVE WITH 1/2" BSPP FEMALE CONNECTIONS.
APPROVED JQ	18/10/23	
BREAK CORNERS 0.005 - 0.010	UNLESS OTHERWISE SPECIFIED, DIMENSIONS ARE IN INCHES	EC NUMBER X INITIAL USAGE (REF ONLY) X CAD FILE NAME
TOLERANCES ARE: .XXX +.005 ANGLES ±.41° .XX +.010 CONCENTRICITY ±0.015 .X +.060 MACHINE FINISH: 63RMS		SIZE A3 SCALE N.T.S. DWG NO. A18663 SHEET 1 OF 1