

MAXIMUM WORKING CONDITIONS
 COLD WORKING PRESSURE:
 STANDARD, 6,000PSI (414BAR)
 (AT REDUCED TEMPERATURE)

TEMPERATURE:
 -29°C (-20.2°F) TO 200°C (392°F)
 (AT REDUCED PRESSURE)

APPROX WEIGHT
 1.2Kg

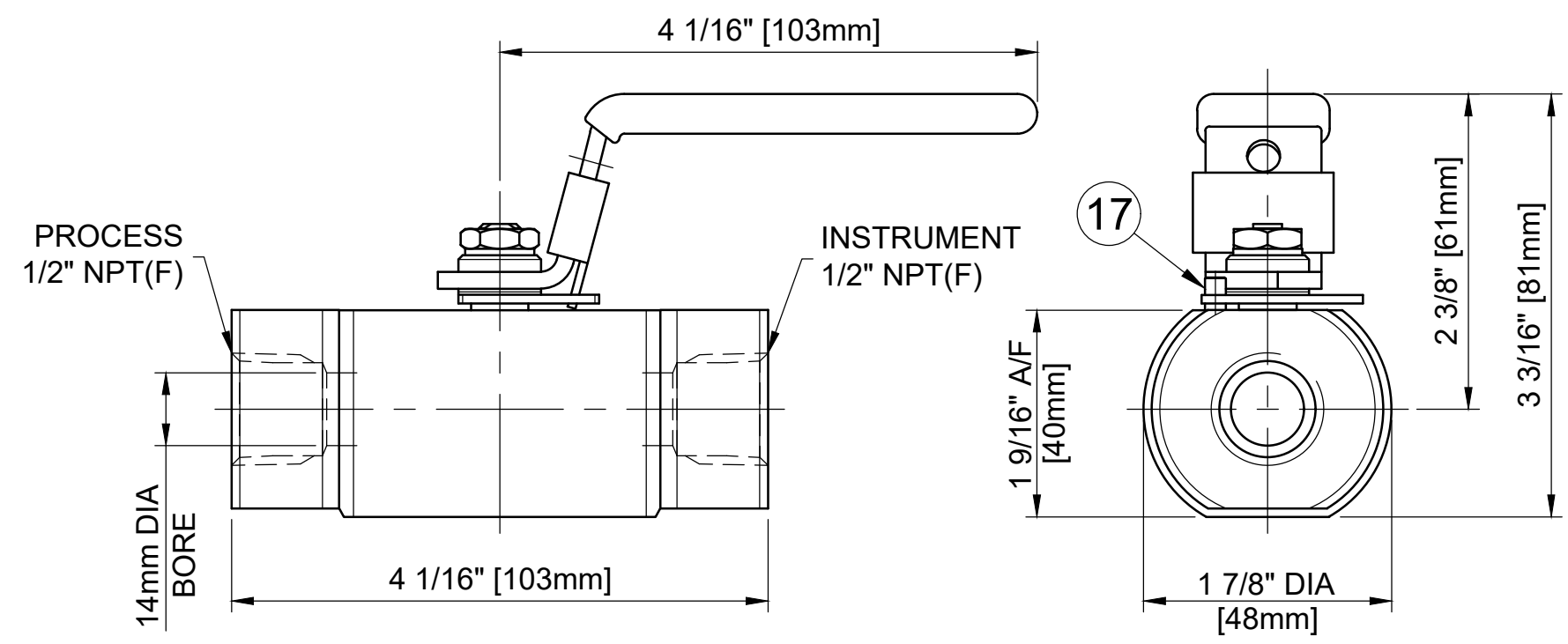

DETAIL 'A'

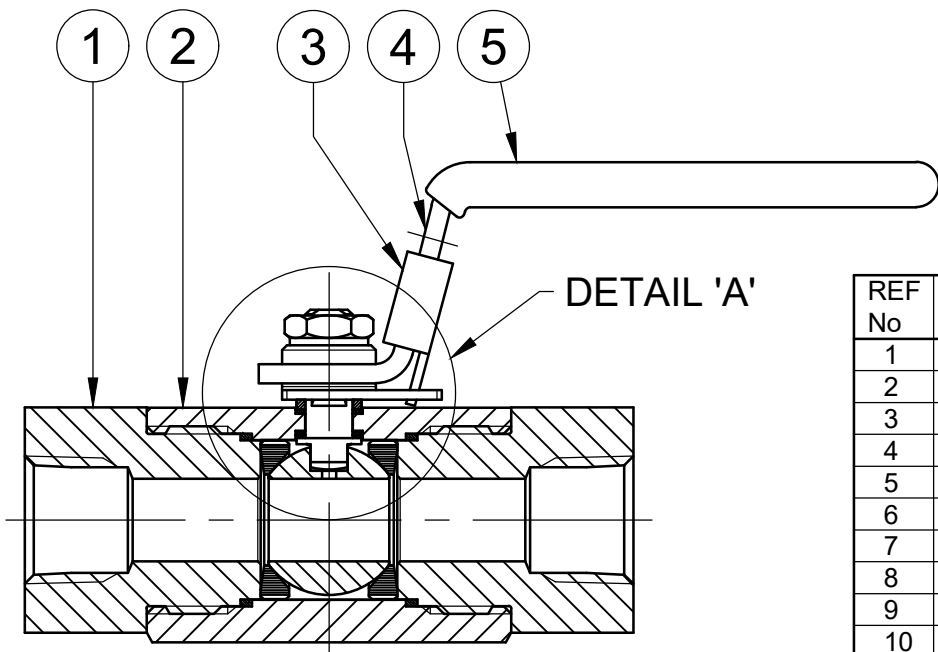
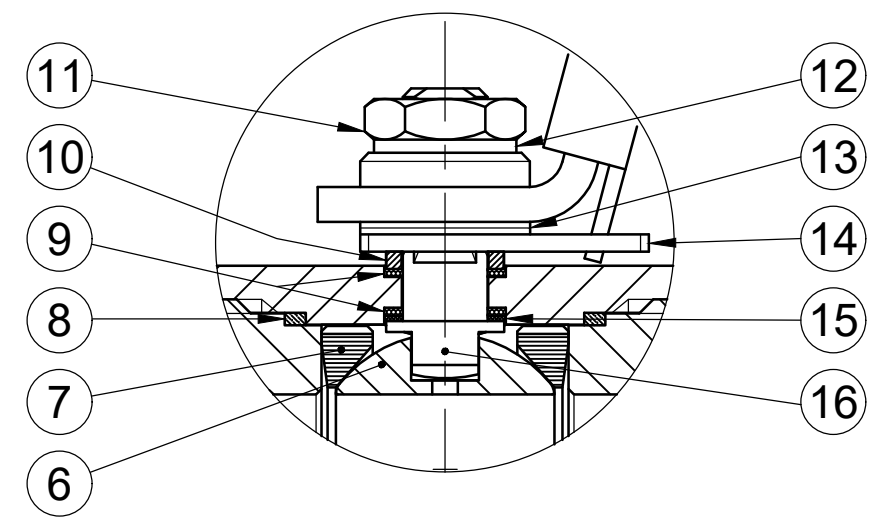

REF No	DESCRIPTION	MATERIAL
		6MO
1	END CONNECTOR	ASTM A276/A479 UNS S31254
2	BODY	ASTM A276/A479 UNS S31254
3	LOCKTAB	316 SS
4	HANDLE	316 SS
5	SLEEVE	PVC
6	BALL	ASTM A276/A479 UNS S31254
7	SEAT	PEEK
8	END CONNECTOR SEAL	100% VIRGIN PTFE
9	SPINDLE SEALS	15% GLASS FILLED PTFE
10	PISTON RING	316 SS
11	NUT	A4 [316] SS
12	SERRATED WASHER	316 SS
13	DISC SPRING	316 SS
14	LOCKING PLATE	316 SS
15	THRUST SEAL	25% GLASS FILLED PTFE
16	SPINDLE	ASTM B446 UNS N06625
17	HANDLE STOP PIN	316 SS

MARKING DETAILS
 (MARKING REFERENCE ONLY)



REMARK

- ADDITIONAL TAG PLATE FOR ADDITIONAL INFO UPON REQUESTED
- HCT HEAT CODE TRACEABILITY WILL BE MARKED ON BODY & END FITTINGS

THE INFORMATION CONTAINED IN THIS DRAWING IS THE PROPERTY OF CRANE COMPANY. ANY REPRODUCTION IN PART OR AS A WHOLE WITHOUT THE WRITTEN PERMISSION OF CRANE COMPANY IS PROHIBITED.

REMOVE ALL BURRS, DO NOT SCALE DRAWING, DRILL POINTS STD

BREAK CORNERS 0.005 - 0.010

UNLESS OTHERWISE SPECIFIED, DIMENSIONS ARE IN INCHES

TOLERANCES ARE:
 .XXX +.005 ANGLES ±.41°
 .XX +.010 CONCENTRICITY ±.0015
 .X +.060 MACHINE FINISH: 63RMS

APPROVALS		DATE
CREATED	ZL	17/10/23
DRAWN	ZL	17/10/23
APPROVED	JQ	18/10/23

EC NUMBER X

INITIAL USAGE (REF ONLY) X

CAD FILE NAME

CRANE	HOKE
SPARTANBURG, SOUTH CAROLINA 29303	
TITLE: GENERAL ARRANGEMENT - 14mm BORE SINGLE ISOLATE BALL VALVE WITH 1/2" NPT FEMALE CONNECTIONS & HANDLE LOCKING.	
SIZE: A3	SCALE: N.T.S.
REV: B	SHEET 1 OF 1