

MAXIMUM WORKING CONDITIONS
COLD WORKING PRESSURE:
 STANDARD, 6,000PSI (414BAR)
 (AT REDUCED TEMPERATURE)

TEMPERATURE:
 -29°C (-20.2°F) TO 240°C (464°F)
 (AT REDUCED PRESSURE)

APPROX WEIGHT
 0.5Kg

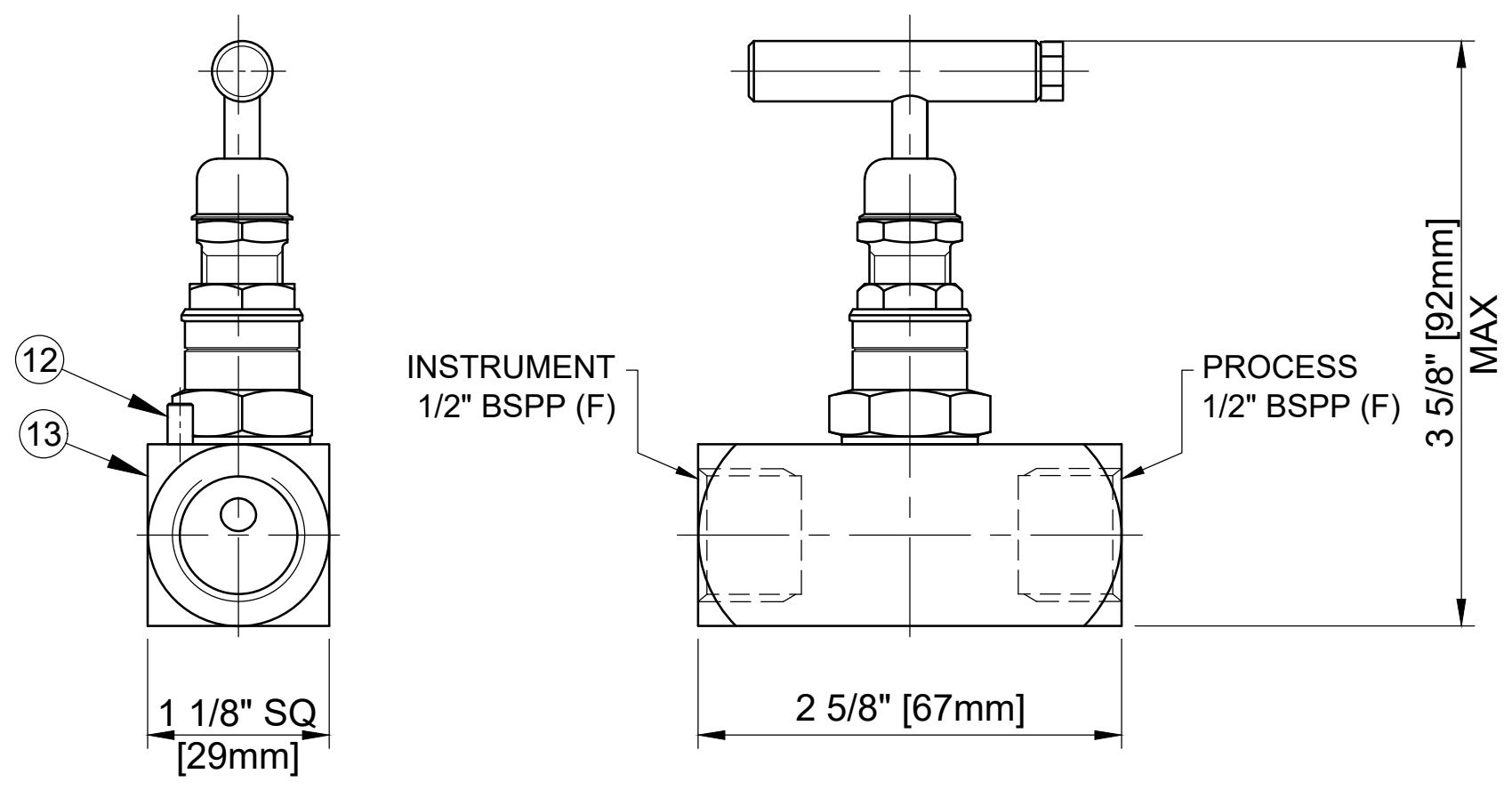

HEADUNIT DETAIL

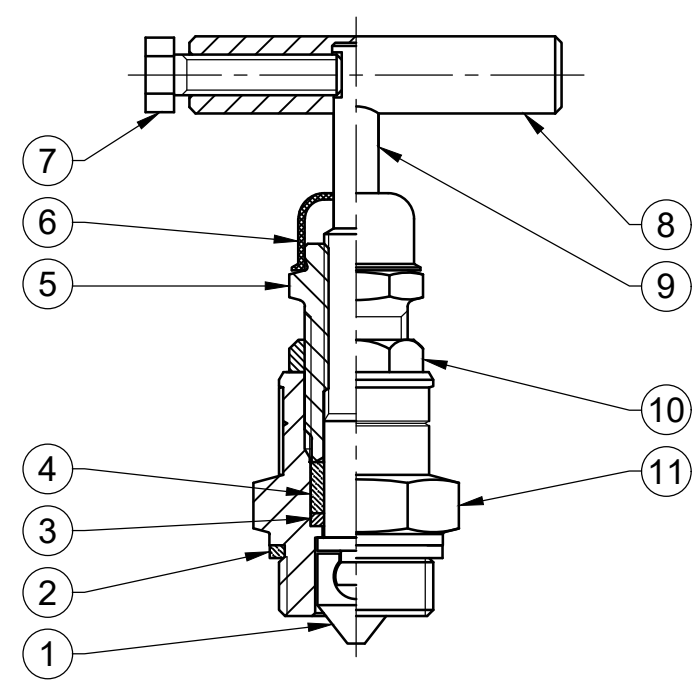

REF No	DESCRIPTION	MATERIAL
		STAINLESS
1	TIP	ASTM A276 /A479 316
2	BODY SEAL	100% VIRGIN PTFE
3	PISTON RING	316 SS
4	SEAL BUSH	100% VIRGIN PTFE
5	PUSHER	316 SS
6	DUST CAP	LOTREX 2300
7	SCREW	A4 [316] SS
8	TEE BAR	316 SS
9	SPINDLE	ASTM A276 /A479 316
10	LOCKNUT	316 SS
11	SEAL HOUSING	ASTM A276 /A479 316
12	LOCK PIN	316 SS
13	BODY	ASTM A276 /A479 316

MARKING DETAILS
 (MARKING REFERENCE ONLY)



REMARK

- ADDITIONAL TAG PLATE FOR ADDITIONAL INFO UPON REQUESTED
- HCT HEAT CODE TRACEABILITY WILL BE MARKED ON BODY & END FITTINGS

THE INFORMATION CONTAINED IN THIS DRAWING IS THE PROPERTY OF CRANE COMPANY. ANY REPRODUCTION IN PART OR AS A WHOLE WITHOUT THE WRITTEN PERMISSION OF CRANE COMPANY IS PROHIBITED.	APPROVALS	DATE	SPARTANBURG, SOUTH CAROLINA 29303
	CREATED ZL	12/10/2023	
REMOVE ALL BURRS, DO NOT SCALE DRAWING, DRILL POINTS STD	DRAWN ZL	12/10/2023	TITLE GENERAL ARRANGEMENT TYPE F50/BP SINGLE ISOLATE NEEDLE VALVE FEMALE x FEMALE CONNECTIONS
BREAK CORNERS 0.005 - 0.010	APPROVED JQ	17/10/2023	
TOLERANCES ARE: .XXX +.005 ANGLES ±.01° .XX +.010 CONCENTRICITY ±.015 X +.060 MACHINE FINISH 63RMS	EC NUMBER	X	SIZE A3 SCALE N.T.S.
	INITIAL USAGE (REF ONLY)	X	
	CAD FILE NAME		SHEET 1 OF 1