

MAXIMUM WORKING CONDITIONS
COLD WORKING PRESSURE:
 SSB-6K OPTION - 6,000PSI (414BAR)
 (AT REDUCED TEMPERATURE)

TEMPERATURE:
 PTFE PACKING -
 -29°C (-20.2°F) TO 240°C (464°F)
 (AT REDUCED PRESSURE)

APPROX WEIGHT
 1.4 Kg

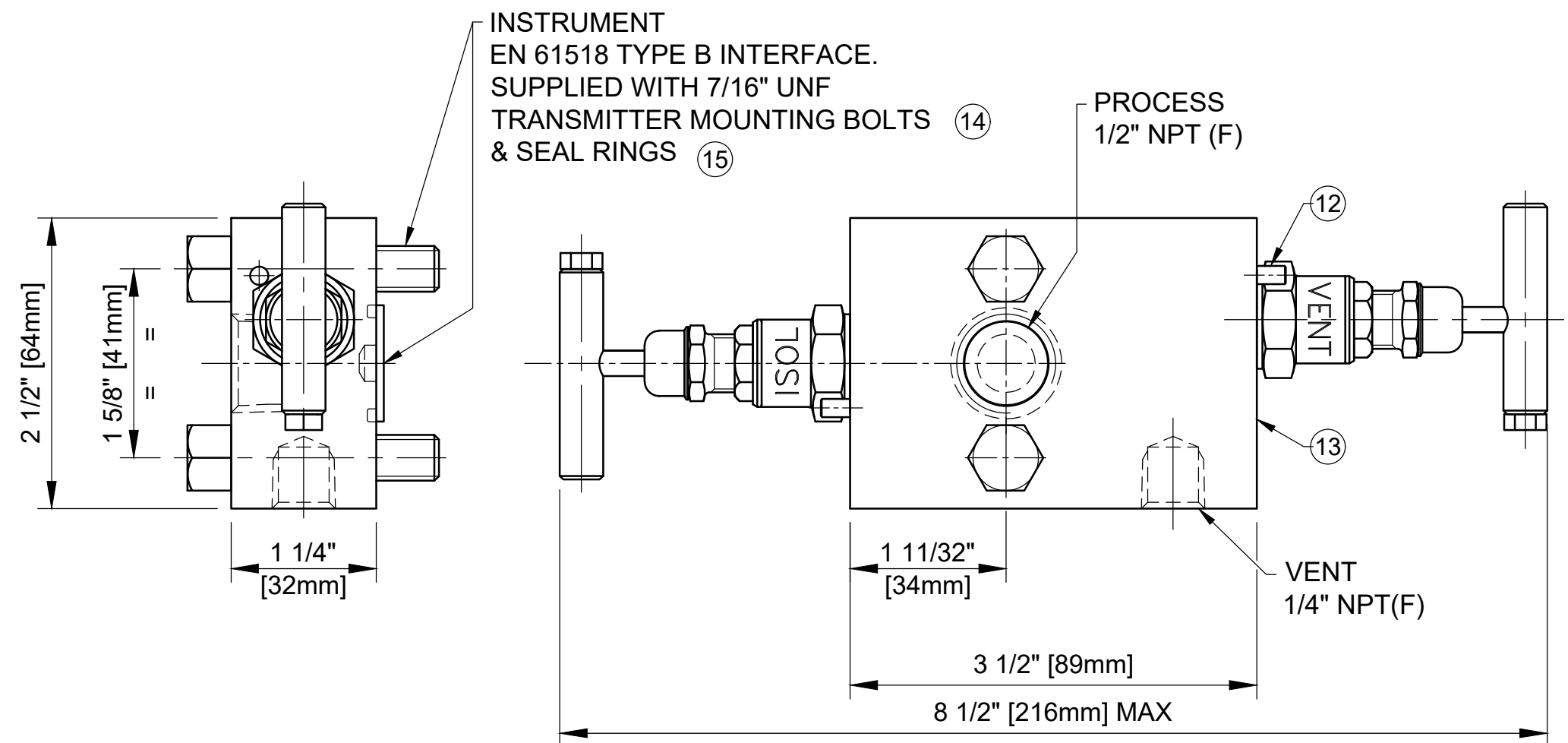

HEADUNIT DETAIL

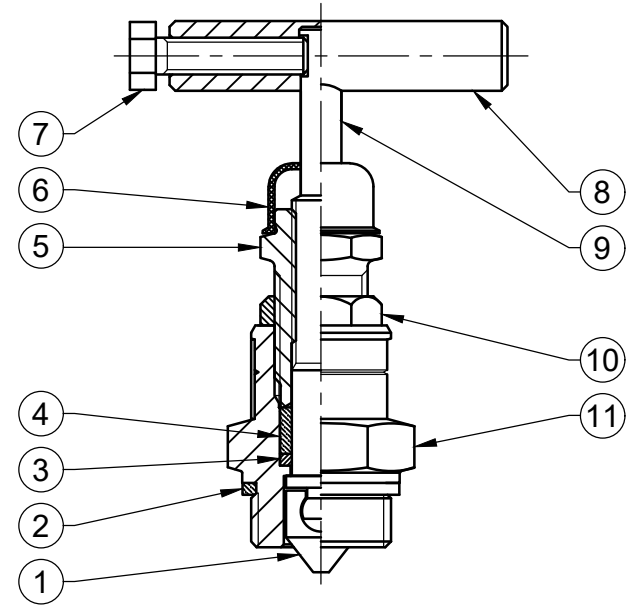

REF No	DESCRIPTION	MATERIAL
		STAINLESS
1	TIP	ASTM A276 /A479 316
2	BODY SEAL	100% VIRGIN PTFE
3	PISTON RING	316 SS
4	SEAL BUSH	100% VIRGIN PTFE
5	PUSHER	316 SS
6	DUST CAP	LOTREX 2300
7	SCREW	A4 [316] SS
8	TEE BAR	316 SS
9	SPINDLE	ASTM A276 /A479 316
10	LOCKNUT	316 SS
11	SEAL HOUSING	ASTM A276 /A479 316
12	LOCK PIN	316 SS
13	BODY	ASTM A276 /A479 316
14	BOLTS	A4-80 SS
15	SEAL RINGS	100% VIRGIN PTFE

MARKING DETAILS
 (MARKING REFERENCE ONLY)



REMARK

- ADDITIONAL TAG PLATE FOR ADDITIONAL INFO UPON REQUESTED
- HCT HEAT CODE TRACEABILITY WILL BE MARKED ON BODY & END FITTINGS

THE INFORMATION CONTAINED IN THIS DRAWING IS THE PROPERTY OF CRANE COMPANY. ANY REPRODUCTION IN PART OR AS A WHOLE WITHOUT THE WRITTEN PERMISSION OF CRANE COMPANY IS PROHIBITED.

APPROVALS: CREATED ZL 12/10/2023, DRAWN ZL 12/10/2023, APPROVED JQ 12/10/2023

REMOVE ALL BURRS, DO NOT SCALE DRAWING, DRILL POINTS STD

BREAK CORNERS 0.005 - 0.010

UNLESS OTHERWISE SPECIFIED, DIMENSIONS ARE IN INCHES

TOLERANCES ARE:
 .XXX +.005 ANGES .01"
 .XX +.010 CONCENTRICITY .0015
 X +.060 MACHINE FINISH 63RMS

CRANE | HOKE
 SPARTANBURG, SOUTH CAROLINA 29303

TITLE: GENERAL ARRANGEMENT TYPE Y24 DIRECT MOUNT PIPE TO FLANGE ISD 61518TYPE-B, 2 VALVE MANIFOLD.

SIZE: A3, SCALE: N.T.S., SHEET 1 OF 1