

MAXIMUM WORKING CONDITIONS
COLD WORKING PRESSURE:
 STANDARD, 6,000PSI (414BAR)
 (AT REDUCED TEMPERATURE)

TEMPERATURE:
 -29°C (-20.2°F) TO 240°C (464°F)
 (AT REDUCED PRESSURE)

APPROX WEIGHT
 1.4Kg

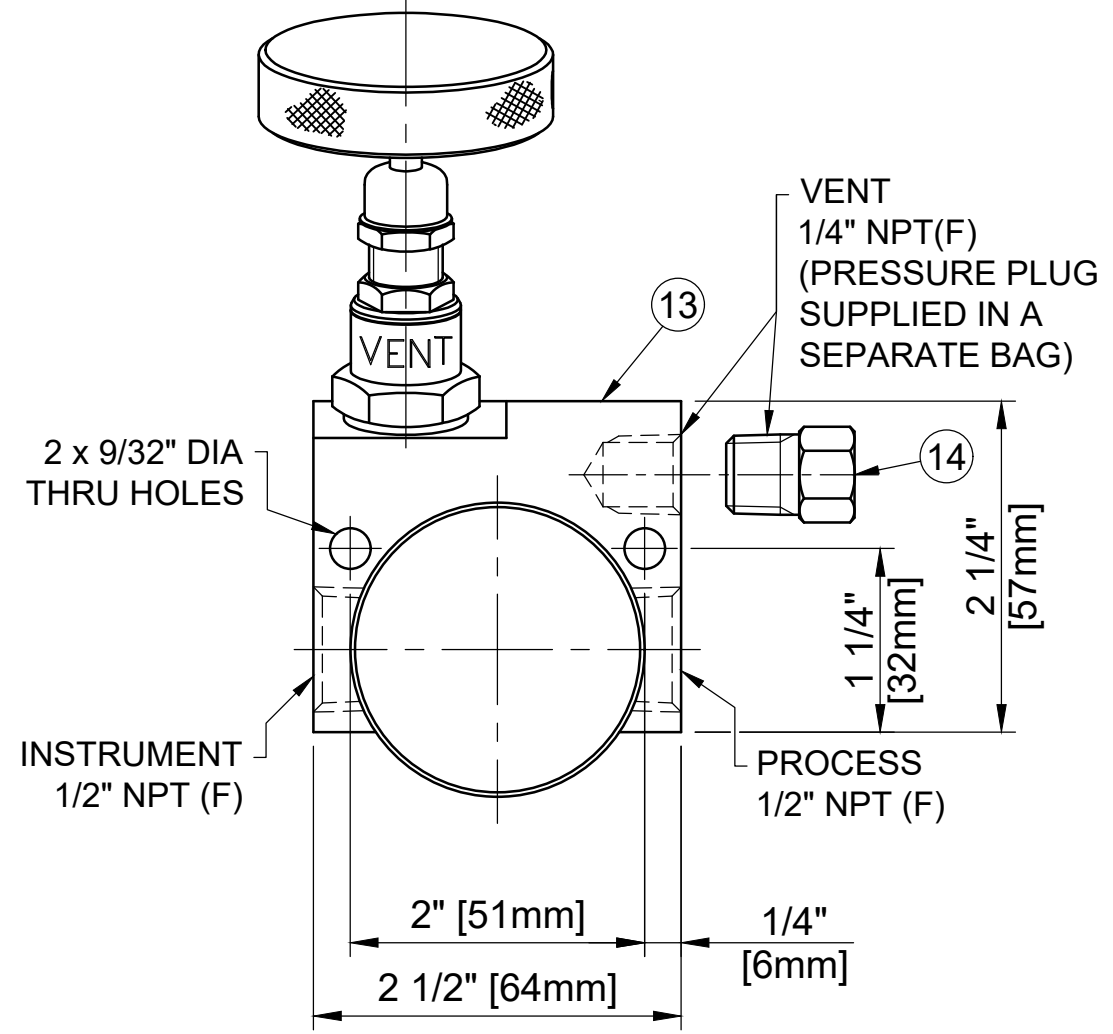
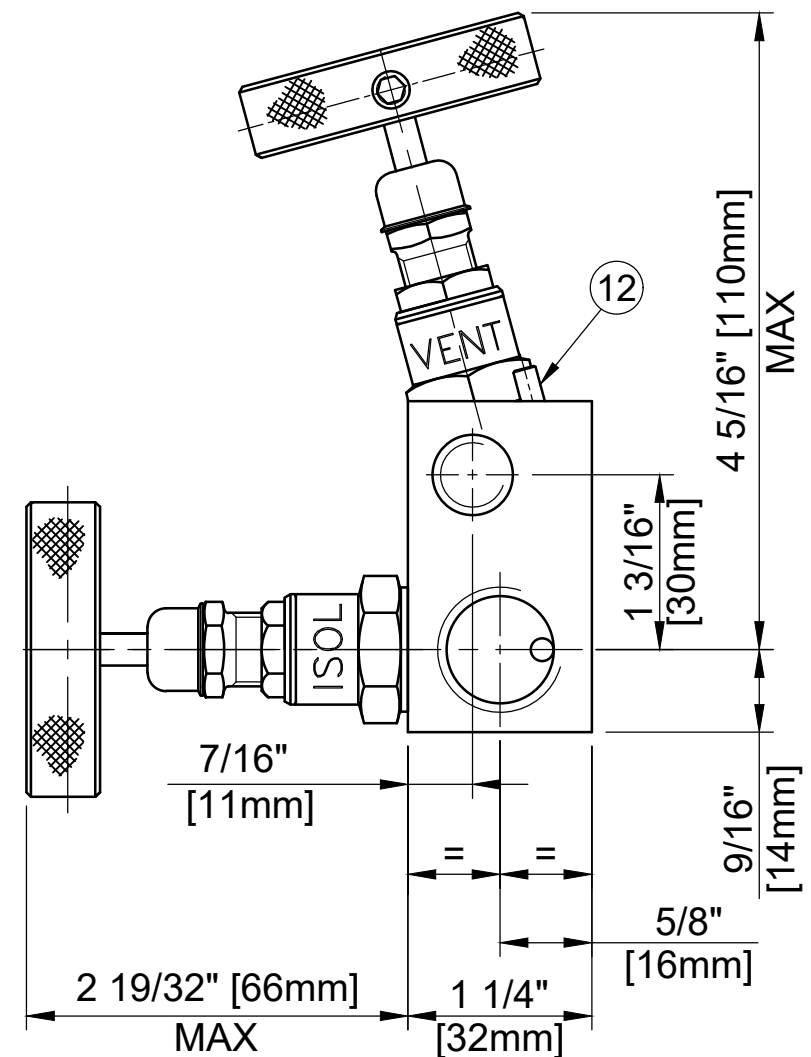

HEADUNIT DETAIL

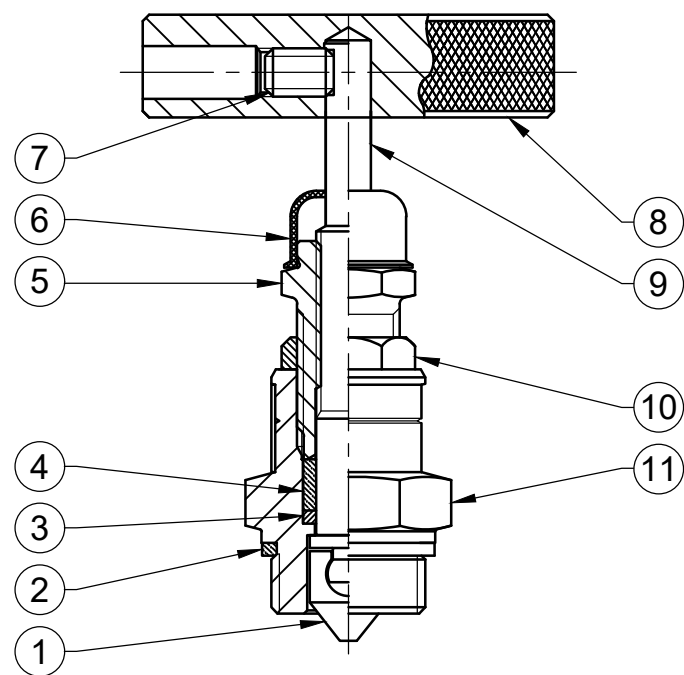

| REF No | DESCRIPTION | MATERIAL |
|--------|---------------|---------------------|
| | | STAINLESS |
| 1 | TIP | ASTM A276 /A479 316 |
| 2 | BODY SEAL | 100% VIRGIN PTFE |
| 3 | PISTON RING | 316 SS |
| 4 | SEAL BUSH | 100% VIRGIN PTFE |
| 5 | PUSHER | 316 SS |
| 6 | DUST CAP | LOTREX 2300 |
| 7 | GRUB SCREW | A4 [316] SS |
| 8 | HANDWHEEL | 316 SS |
| 9 | SPINDLE | ASTM A276 /A479 316 |
| 10 | LOCKNUT | 316 SS |
| 11 | SEAL HOUSING | ASTM A276 /A479 316 |
| 12 | LOCK PIN | 316 SS |
| 13 | BODY | ASTM A276 /A479 316 |
| 14 | PRESSURE PLUG | ASTM A276 /A479 316 |

MARKING DETAILS
 (MARKING REFERENCE ONLY)



REMARK
 • ADDITIONAL TAG PLATE FOR ADDITIONAL INFO UPON REQUESTED
 • HCT HEAT CODE TRACEABILITY WILL BE MARKED ON BODY & END FITTINGS

THE INFORMATION CONTAINED IN THIS DRAWING IS THE PROPERTY OF CRANE COMPANY. ANY REPRODUCTION IN PART OR AS A WHOLE WITHOUT THE WRITTEN PERMISSION OF CRANE COMPANY IS PROHIBITED.

| | | |
|-----------------------------|--|---|
| APPROVALS | DATE | |
| CREATED ZL | 11/10/2023 | |
| DRAWN ZL | 11/10/2023 | SPARTANBURG, SOUTH CAROLINA 29303 TITLE GENERAL ARRANGEMENT TYPE G12AF 1/2" FEMALE x FEMALE GAUGE ISOLATE VALVE WITH HANDWHEEL |
| APPROVED JQ | 17/10/2023 | |
| BREAK CORNERS 0.005 - 0.010 | UNLESS OTHERWISE SPECIFIED, DIMENSIONS ARE IN INCHES | SIZE A3 |
| TOLERANCES ARE: | ANGLES ± 1° | SCALE N.T.S. |
| .XXX + .005 | CONCENTRICITY ± 0.015 | ECOM NO XXXXX |
| .XX + .010 | MACHINE FINISH 63RMS | DWG NO A18697 |
| .X + .060 | | SHEET 1 OF 1 |

APPROVALS: ZL, JQ, X
 DATE: 11/10/2023, 17/10/2023
 EC NUMBER: X
 INITIAL USAGE (REF ONLY): X
 CAD FILE NAME: [blank]