

MAXIMUM WORKING CONDITIONS
COLD WORKING PRESSURE:
 STANDARD, 6,000PSI (414BAR)
 (AT REDUCED TEMPERATURE)

TEMPERATURE:
 PTFE PACKING -
 -29°C (-20.2°F) TO 240°C (464°F)
 (AT REDUCED PRESSURE)

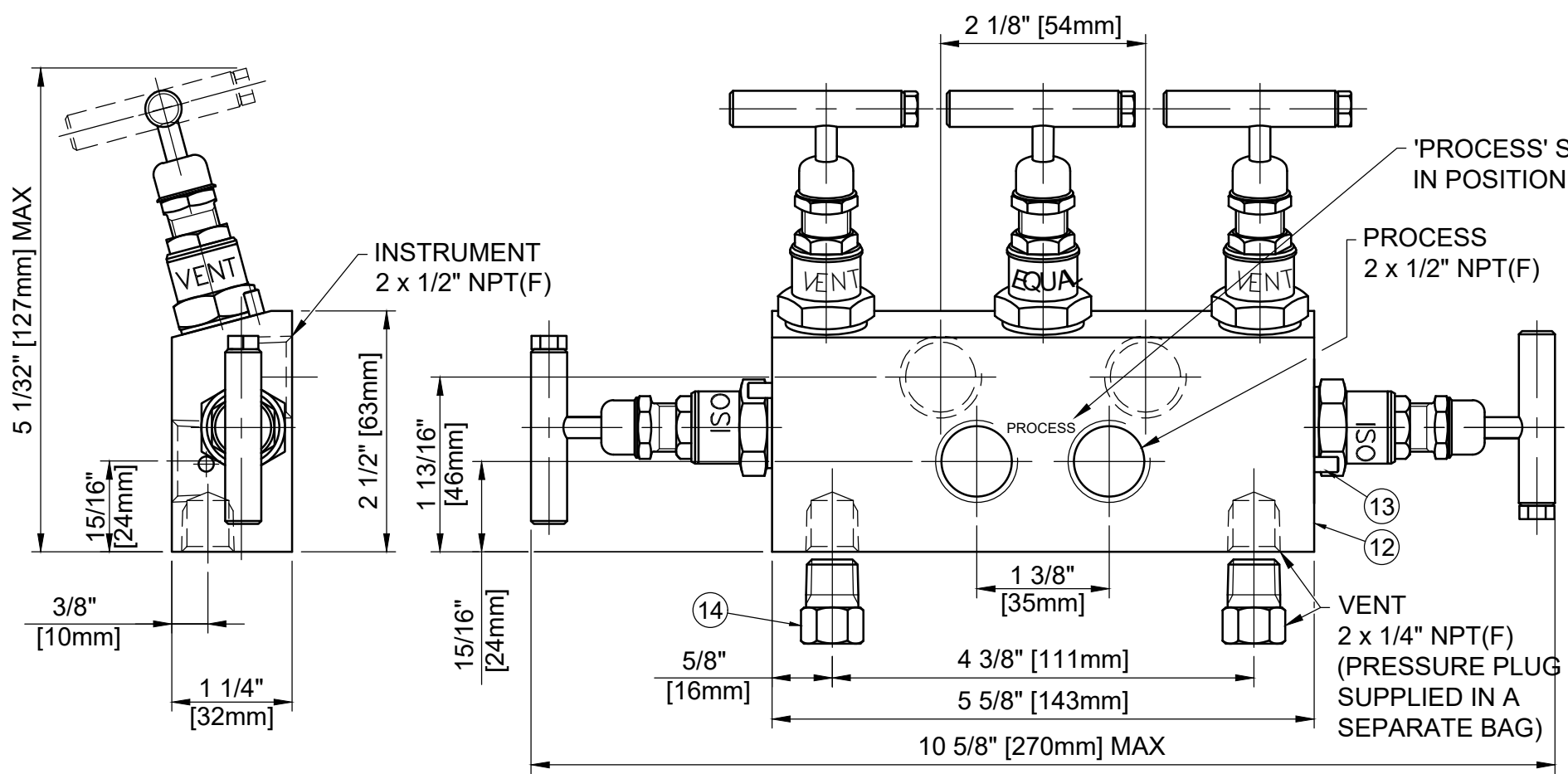

APPROX WEIGHT
 2.3 Kg

HEADUNIT DETAIL

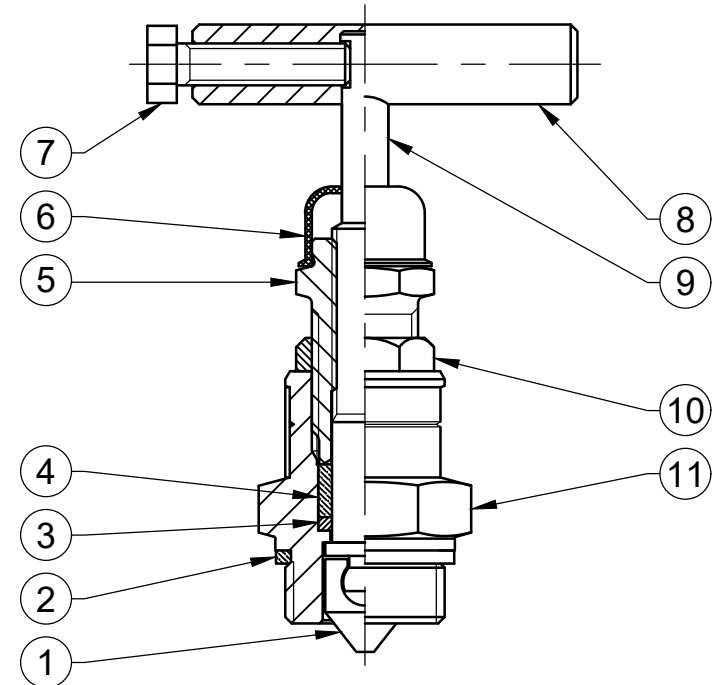

REF No	DESCRIPTION	MATERIAL
		STAINLESS
1	TIP	ASTM A276/A479 316
2	BODY SEAL	100% VIRGIN PTFE
3	PISTON RING	316 SS
4	SEAL BUSH	100% VIRGIN PTFE
5	PUSHER	316 SS
6	DUST CAP	LOTREX 2300
7	SCREW	A4 [316] SS
8	TEE BAR	316 SS
9	SPINDLE	ASTM A276/A479 316
10	LOCKNUT	316 SS
11	SEAL HOUSING	ASTM A276/A479 316
12	BODY	ASTM A276/A479 316
13	STOP PIN	316 SS
14	PRESSURE PLUG	ASTM A276/A479 316

MARKING DETAILS
 (MARKING REFERENCE ONLY)



REMARK

- ADDITIONAL TAG PLATE FOR ADDITIONAL INFO UPON REQUESTED
- HCT HEAT CODE TRACEABILITY WILL BE MARKED ON BODY & END FITTINGS

THE INFORMATION CONTAINED IN THIS DRAWING IS THE PROPERTY OF CRANE COMPANY. ANY REPRODUCTION IN PART OR AS A WHOLE WITHOUT THE WRITTEN PERMISSION OF CRANE COMPANY IS PROHIBITED.

REMOVE ALL BURRS, DO NOT SCALE DRAWING, DRILL POINTS STD

BREAK CORNERS 0.005 - 0.010

UNLESS OTHERWISE SPECIFIED, DIMENSIONS ARE IN INCHES

TOLERANCES ARE:
 .XXX +.005 ANGLES ±.1°
 .XX +.010 CENTRICITY ±.0015
 .X +.060 MACHINE FINISH: 63RMS

APPROVALS		DATE
CREATED	ZL	09/10/2023
DRAWN	ZL	09/10/2023
APPROVED	JQ	12/10/2023

EC NUMBER X

INITIAL USAGE (REF ONLY) X

CAD FILE NAME

CRANE HOKÉ
 SPARTANBURG, SOUTH CAROLINA 29303

TITLE: GENERAL ARRANGEMENT TYPE Y54 PIPE TO PIPE 5 V/V MANIFOLD

SIZE: A3
 SCALE: N.T.S.
 DWG NO: A18706
 SHEET 1 OF 1