

**MAXIMUM WORKING CONDITIONS**  
**COLD WORKING PRESSURE:**  
 HIGH PRESSURE, 10,000PSI (690BAR)  
 (AT REDUCED TEMPERATURE)

**TEMPERATURE:**  
 PTFE PACKING -  
 -29°C (-20.2°F) TO 240°C (464°F)  
 (AT REDUCED PRESSURE)

APPROX WEIGHT  
2.5 Kg

**MARKING DETAILS**  
 (MARKING REFERENCE ONLY)

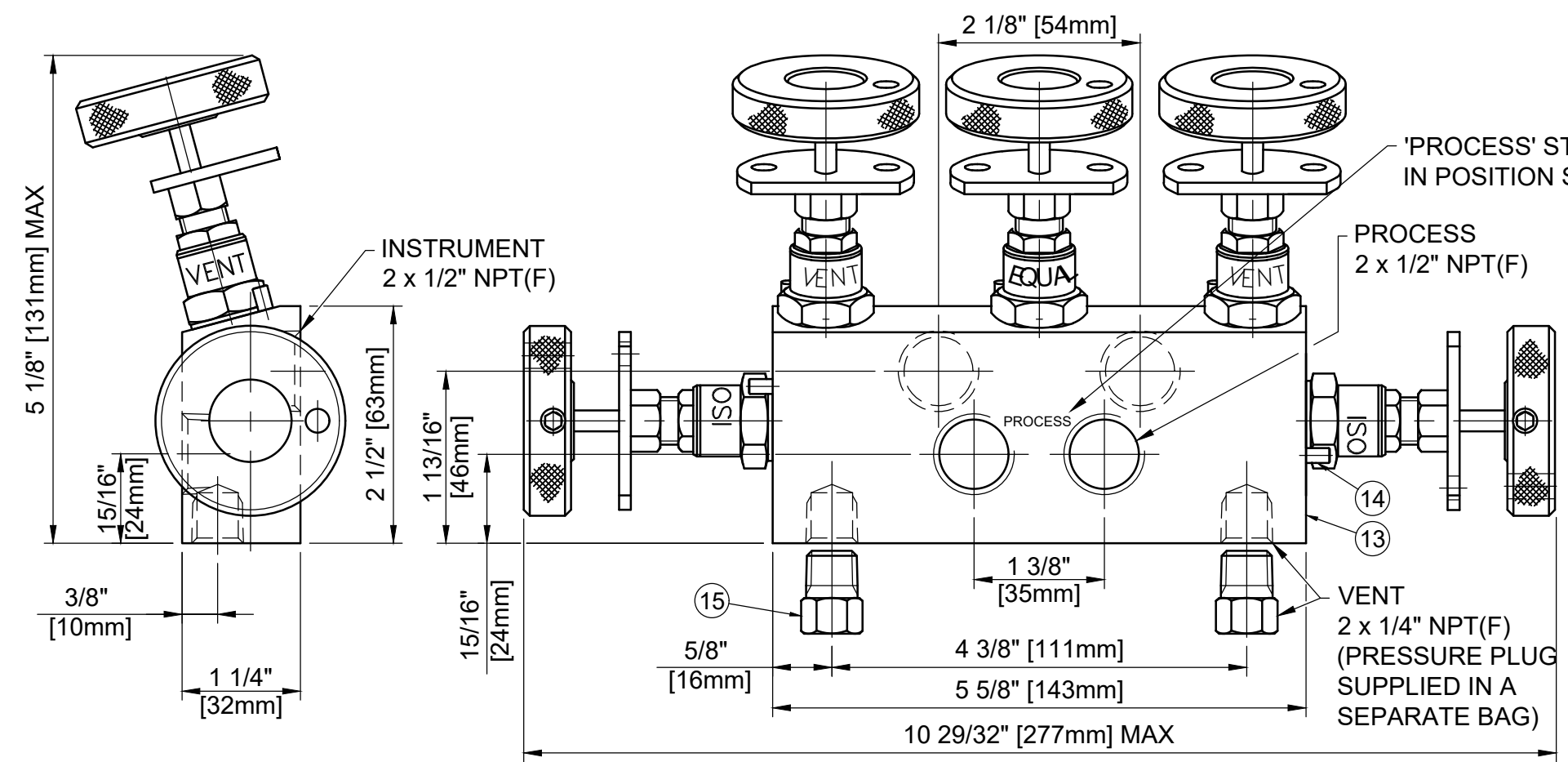

**HEADUNIT DETAIL**

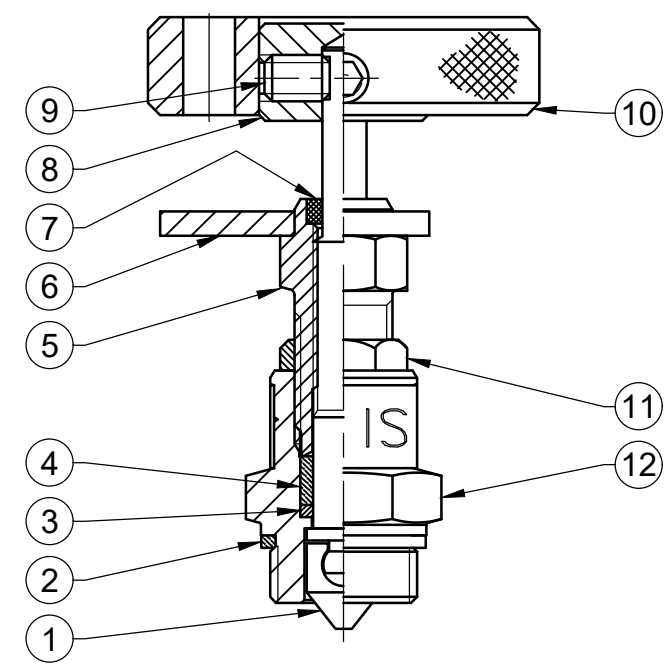

REF No	DESCRIPTION	MATERIAL
		STAINLESS
1	SPINDLE & TIP	ASTM A276/A479 316
2	BODY SEAL	100% VIRGIN PTFE
3	PISTON RING	316 SS
4	SEAL BUSH	100% VIRGIN PTFE
5	PUSHER	316 SS
6	LOCKING PLATE	316 SS
7	DUST SEAL	100% VIRGIN PTFE
8	HANDWHEEL INSERT	316 SS
9	GRUB SCREW	A4 [316] SS
10	LOCKING HANDWHEEL	ALUMINIUM
11	LOCKNUT	316 SS
12	SEAL HOUSING	ASTM A276/A479 316
13	BODY	ASTM A276/A479 316
14	STOP PIN	316 SS
15	PRESSURE PLUG	ASTM A276/A479 316

**REMARK**

- ADDITIONAL TAG PLATE FOR ADDITIONAL INFO UPON REQUESTED
- HCT HEAT CODE TRACEABILITY WILL BE MARKED ON BODY & END FITTINGS

THE INFORMATION CONTAINED IN THIS DRAWING IS THE PROPERTY OF CRANE COMPANY. ANY REPRODUCTION IN PART OR AS A WHOLE WITHOUT THE WRITTEN PERMISSION OF CRANE COMPANY IS PROHIBITED. REMOVE ALL BURRS, DO NOT SCALE DRAWING, DRILL POINTS STD BREAK CORNERS 0.005 - 0.010 UNLESS OTHERWISE SPECIFIED, DIMENSIONS ARE IN INCHES TOLERANCES ARE: .XXX +.005 .XX +.010 .X +.060 ANGLES ±.41° CONCENTRICITY ±.0015 MACHINE FINISH: 63RMS	APPROVALS CREATED ZL 09/10/2023 DRAWN ZL 09/10/2023 APPROVED JQ 12/10/2023 EC NUMBER X INITIAL USAGE (REF ONLY) X CAD FILE NAME	DATE 09/10/2023 09/10/2023 12/10/2023	CRANE   HOKE SPARTANBURG, SOUTH CAROLINA 29303 TITLE: GENERAL ARRANGEMENT TYPE Y54 PIPE TO PIPE 5 V/V MANIFOLD WITH LOCKING HANDWHEEL SIZE: A3 SCALE: N.T.S. SHEET 1 OF 1
	SHEET 1 OF 1		REV B