

MAXIMUM WORKING CONDITIONS
COLD WORKING PRESSURE:
 STANDARD, 6,000PSI (414BAR)
 (AT REDUCED TEMPERATURE)

TEMPERATURE:
 -29°C (-20.2°F) TO 200°C (392°F)
 (AT REDUCED PRESSURE)

APPROX WEIGHT
 4.8Kg

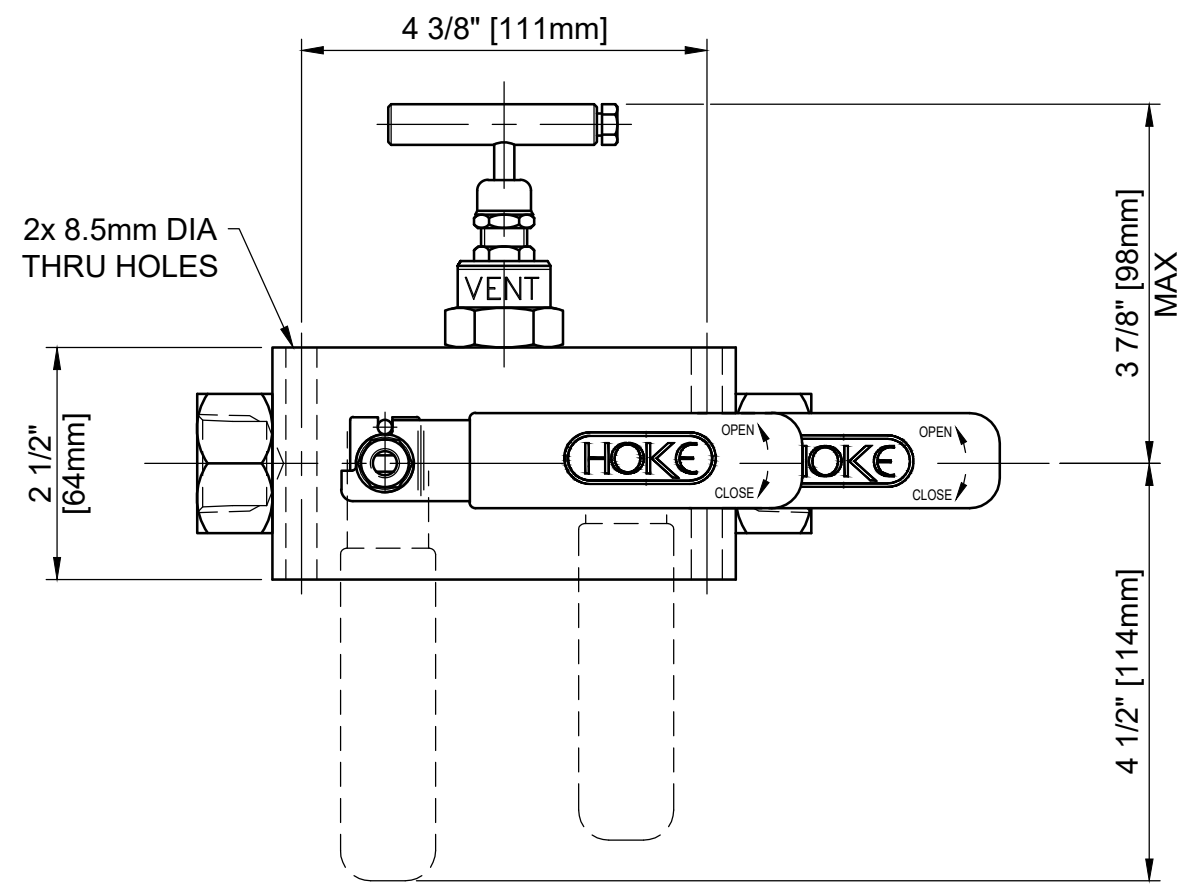

REF No	DESCRIPTION	MATERIAL
1	PROCESS CONNECTOR	ASTM A276/A479 316
2	BODY	ASTM A276/A479 316
3	INSTRUMENT CONNECTOR	ASTM A276/A479 316
4	SLEEVE	PVC
5	HANDLE	316 SS
6	NUT	A4 [316] SS
7	SERRATED WASHER	316 SS
8	PISTON RING	316 SS
9	THRUST SEAL	25% GLASS FILLED PTFE
10	SEAT	PEEK
11	BALL	ASTM A276/A479 316
12	SPINDLE	ASTM A276/A479 UNS S31803
13	END CONNECTOR SEAL	100% VIRGIN PTFE
14	SPINDLE O-RING	ELAST-O-LION 985
15	SPINDLE SEALS	15% GLASS FILLED PTFE
16	HANDLE STOP PIN	316 SS
17	SPINDLE&TIP	ASTM A276/A479 316
18	BODY SEAL	GRAPHITE
19	SEAL BUSH	GRAPHITE
20	PISTON RING	316 SS
21	PUSHER	316 SS
22	DUST CAP	LOTREX 2300
23	SCREW	A4 [316] SS
24	TEE BAR	316 SS
25	LOCKNUT	316 SS
26	SEAL HOUSING	ASTM A276/A479 316
27	PRESSURE PLUG	ASTM A276/A479 316

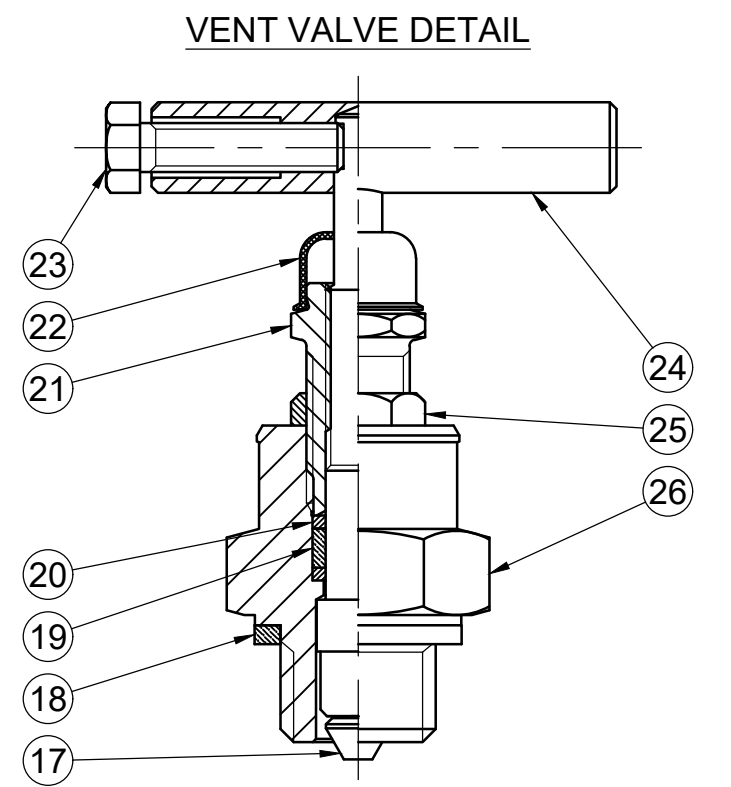
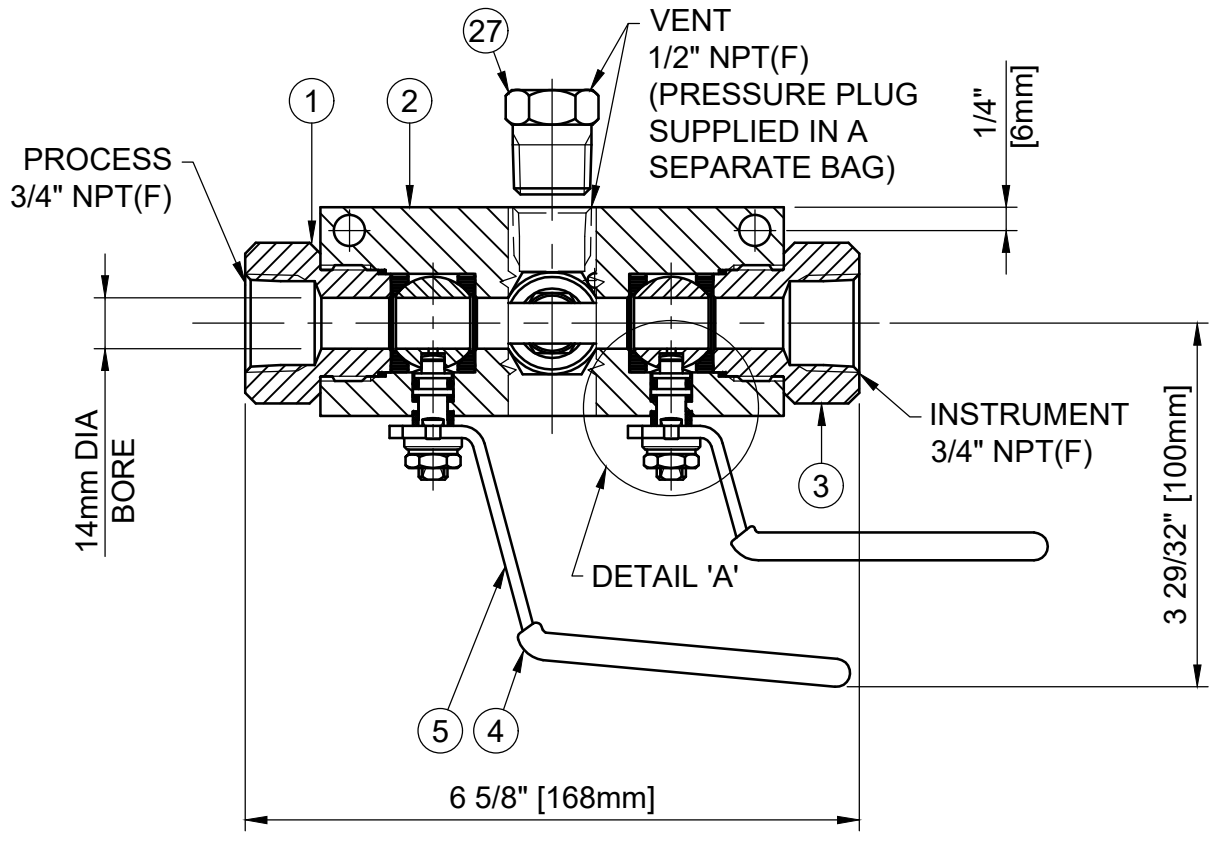
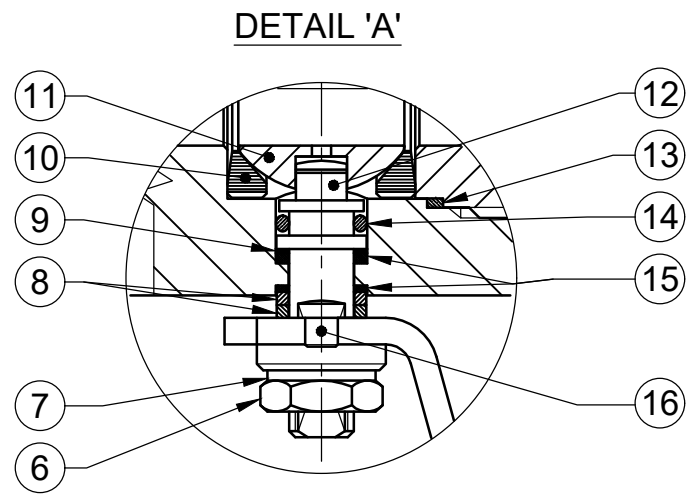

MARKING DETAILS
 (MARKING REFERENCE ONLY)



REMARK

- ADDITIONAL TAG PLATE FOR ADDITIONAL INFO UPON REQUESTED
- HCT HEAT CODE TRACEABILITY WILL BE MARKED ON BODY & END FITTINGS

THE INFORMATION CONTAINED IN THIS DRAWING IS THE PROPERTY OF CRANE COMPANY. ANY REPRODUCTION IN PART OR AS A WHOLE WITHOUT THE WRITTEN PERMISSION OF CRANE COMPANY IS PROHIBITED.		APPROVALS CREATED JQ 12/10/2023 DRAWN JQ 12/10/2023 APPROVED ZL 18/10/2023		DATE 12/10/2023 18/10/2023		CRANE HOKE SPARTANBURG, SOUTH CAROLINA 29303	
REMOVE ALL BURRS, DO NOT SCALE DRAWING, DRILL POINTS STD		EC NUMBER X		TITLE GENERAL ARRANGEMENT - 14mm BORE 'ID' TYPE DOUBLE BLOCK & BLEED MANIFOLD.		SIZE A3 SCALE N.T.S.	
BREAK CORNERS 0.005 - 0.010		UNLESS OTHERWISE SPECIFIED, DIMENSIONS ARE IN INCHES		INITIAL USAGE (REF ONLY) X		DWG NO. A18672 SHEET 1 OF 1	
TOLERANCES ARE: .XXX +.005 .XX +.010 .X +.060		ANGLES ±41° CONCENTRICITY ±0.015 MACHINE FINISH: 63RMS		CAD FILE NAME		REV C	