

MAXIMUM WORKING CONDITIONS
 COLD WORKING PRESSURE:
 STANDARD, 6,000PSI (414BAR)
 (AT REDUCED TEMPERATURE)

TEMPERATURE:
 -29°C (-20.2°F) TO 200°C (392°F)
 (AT REDUCED PRESSURE)

APPROX WEIGHT
 5.8Kg

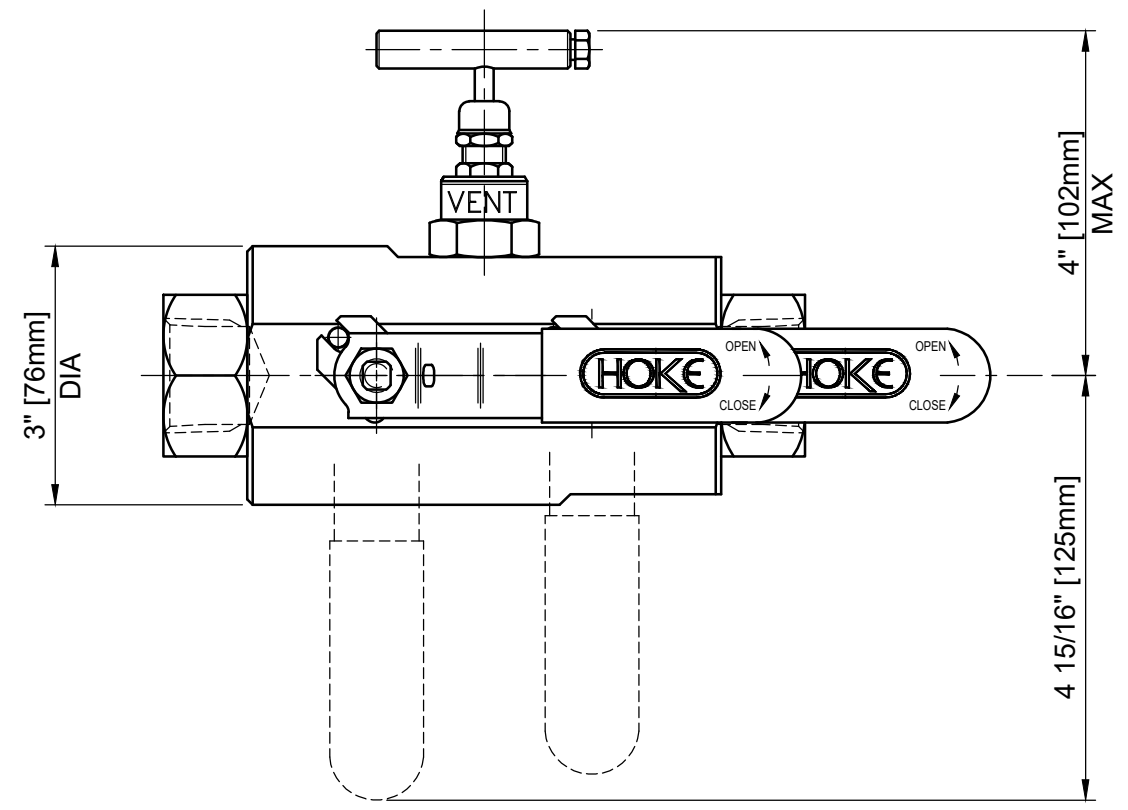

REF No	DESCRIPTION	MATERIAL
		STAINLESS
1	PROCESS CONNECTOR	ASTM A276/A479 316
2	BODY	ASTM A276/A479 316
3	INSTRUMENT CONNECTOR	ASTM A276/A479 316
4	SLEEVE	PVC
5	HANDLE	316 SS
6	NUT	A4 [316] SS
7	HANDLE STOP PIN	316 SS
8	ANTI TORQUE PLATE	316 SS
9	SPINDLE SEALS	100% VIRGIN PTFE
10	SEAT	PEEK
11	BALL	ASTM A276/A479 316
12	CONNECTOR SEAL	100% VIRGIN PTFE
13	THRUST WASHER	PEEK
14	SPINDLE	ASTM A276/A479 316
15	PISTON RING	316 SS
16	DISC SPRINGS	316 SS
17	FRICTION WASHER	PEEK
18	SPINDLE&TIP	ASTM A276/A479 316
19	BODY SEAL	GRAPHITE
20	SEAL BUSH	GRAPHITE
21	PISTON RING	316 SS
22	PUSHER	316 SS
23	DUST CAP	LOTREX 2300
24	SCREW	A4 [316] SS
25	TEE BAR	316 SS
26	LOCKNUT	316 SS
27	SEAL HOUSING	ASTM A276/A479 316
28	PRESSURE PLUG	ASTM A276/A479 316

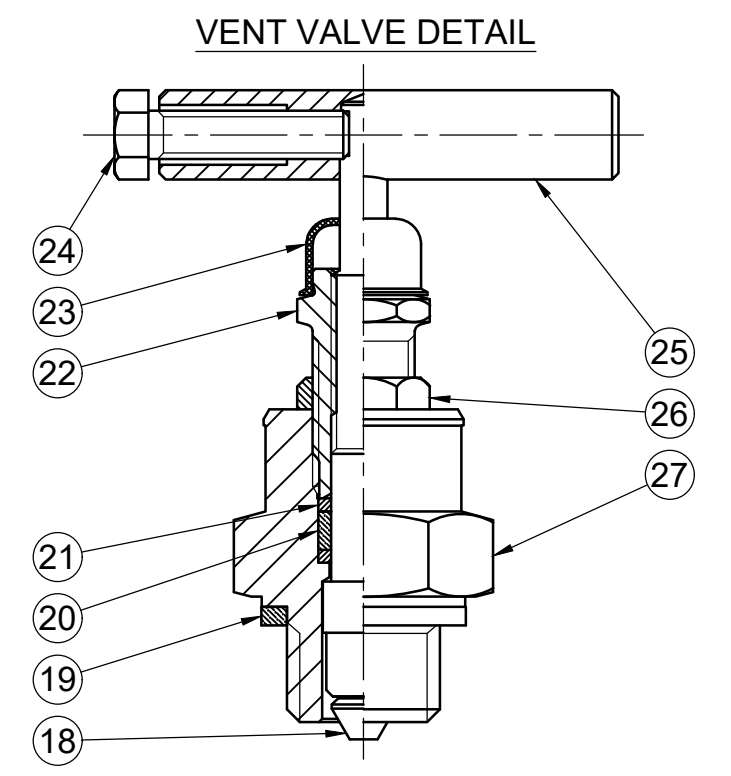
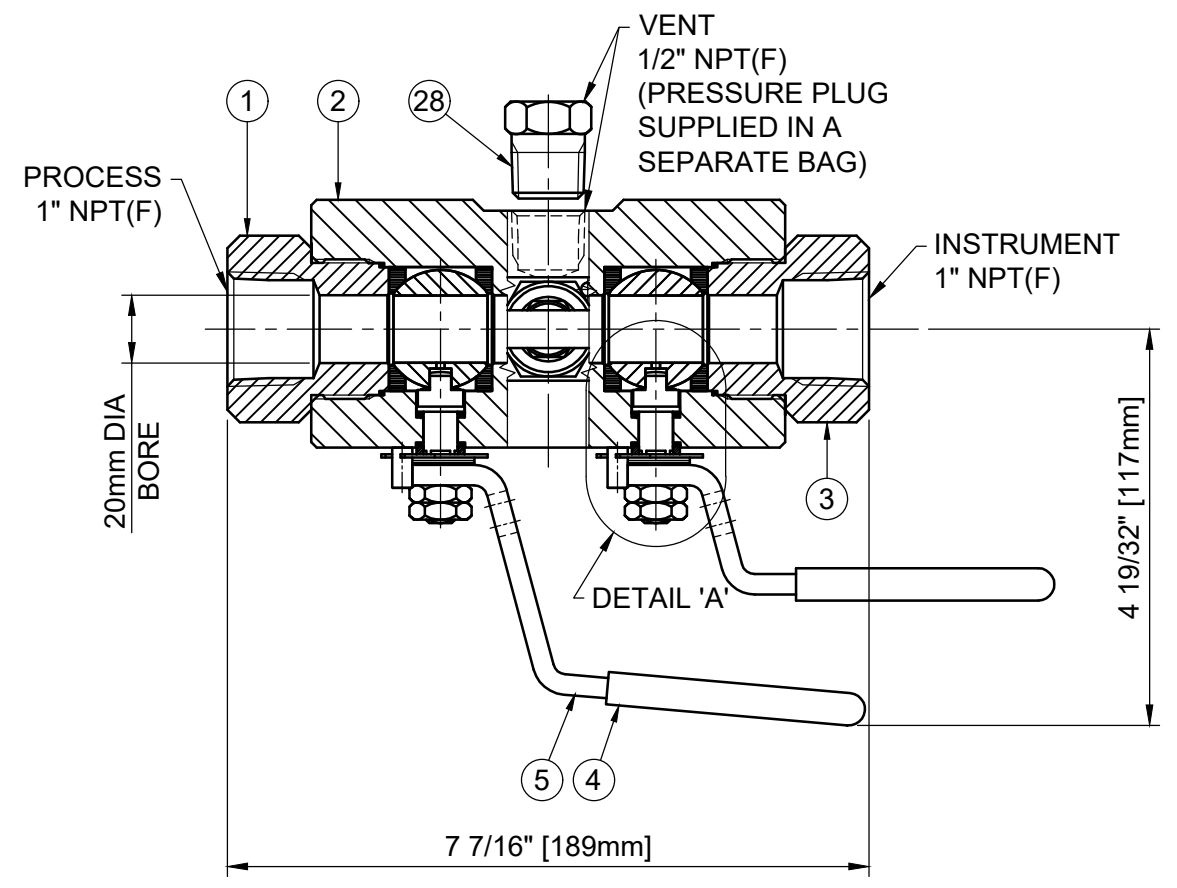
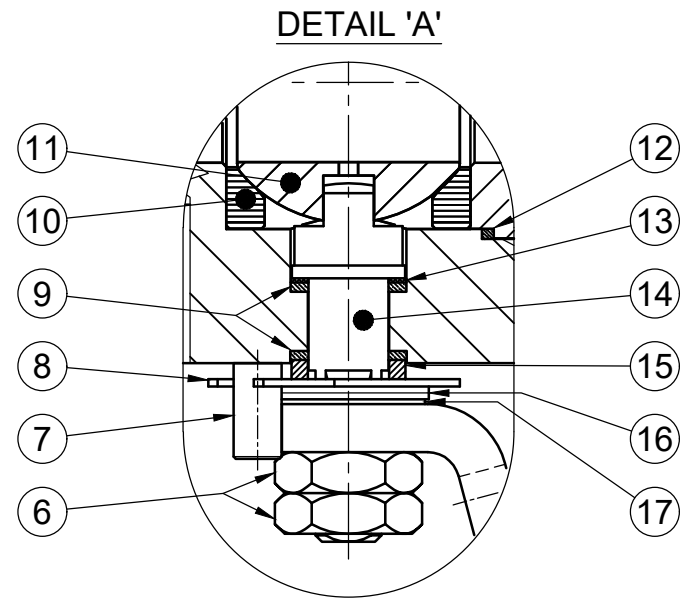

MARKING DETAILS
 (MARKING REFERENCE ONLY)



REMARK

- ADDITIONAL TAG PLATE FOR ADDITIONAL INFO UPON REQUESTED
- HCT HEAT CODE TRACEABILITY WILL BE MARKED ON BODY & END FITTINGS

THE INFORMATION CONTAINED IN THIS DRAWING IS THE PROPERTY OF CRANE COMPANY. ANY REPRODUCTION IN PART OR AS A WHOLE WITHOUT THE WRITTEN PERMISSION OF CRANE COMPANY IS PROHIBITED.		APPROVALS		DATE	
REMOVE ALL BURRS, DO NOT SCALE DRAWING, DRILL POINTS STD		CREATED	JQ	13/10/2023	
BREAK CORNERS 0.005 - 0.010		DRAWN	JQ	13/10/2023	TITLE GENERAL ARRANGEMENT - 20mm BORE 'ID' TYPE DOUBLE BLOCK & BLEED MANIFOLD.
UNLESS OTHERWISE SPECIFIED, DIMENSIONS ARE IN INCHES		APPROVED	ZL	18/10/2023	
TOLERANCES ARE: .XXX +.005 ANGLES ±.01° .XX +.010 CONCENTRICITY ±.015 X +.060 MACHINE FINISH 63RMS		EC NUMBER	X		SIZE A3 SCALE N.T.S.
		INITIAL USAGE (REF ONLY)	X		DWG NO. A18674 SHEET 1 OF 1
		CAD FILE NAME			REV B