

**MAXIMUM WORKING CONDITIONS**  
**COLD WORKING PRESSURE:**  
 STANDARD, 6,000PSI (414BAR)  
 (AT REDUCED TEMPERATURE)

**TEMPERATURE:**  
 -29°C (-20.2°F) TO 200°C (392°F)  
 (AT REDUCED PRESSURE)

APPROX WEIGHT  
 2.0Kg

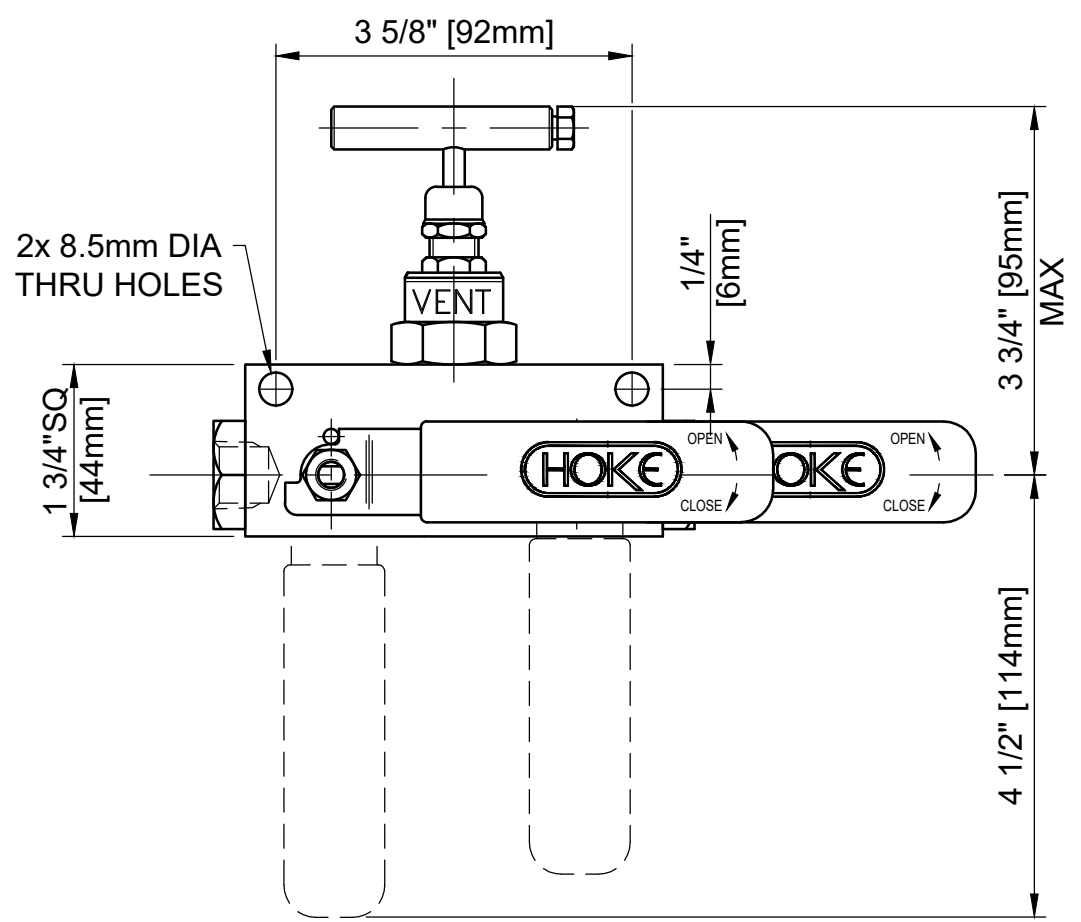

REF No	DESCRIPTION	MATERIAL
		STAINLESS
1	PROCESS CONNECTOR	ASTM A276 /A479 316
2	BODY	ASTM A276 /A479 316
3	INSTRUMENT CONNECTOR	ASTM A276 /A479 316
4	SLEEVE	PVC
5	HANDLE	316 SS
6	NUT	A4 [316] SS
7	SERRATED WASHER	316 SS
8	SPINDLE	ASTM A276 /A479 316
9	THRUST SEAL	25% GLASS FILLED PTFE
10	SEAT CARRIER SEAL	GRAPHITE
11	SEAT CARRIER	ASTM A276 /A479 316
12	BALL	ASTM A276 /A479 316
13	SEAT	25% GLASS FILLED PTFE/PCTFE
14	BODY SEAL	100% VIRGIN PTFE
15	SPINDLE SEAL	15% GLASS FILLED PTFE
16	PISTON RING	316 SS
17	HANDLE STOP PIN	316 SS
18	SPINDLE&TIP	ASTM A276 /A479 316
19	BODY SEAL	GRAPHITE
20	SEAL BUSH	GRAPHITE
21	PISTON RING	316 SS
22	PUSHER	316 SS
23	DUST CAP	LOTREX 2300
24	SCREW	A4 [316] SS
25	TEE BAR	316 SS
26	LOCKNUT	316 SS
27	SEAL HOUSING	ASTM A276 /A479 316
28	PRESSURE PLUG	ASTM A276 /A479 316

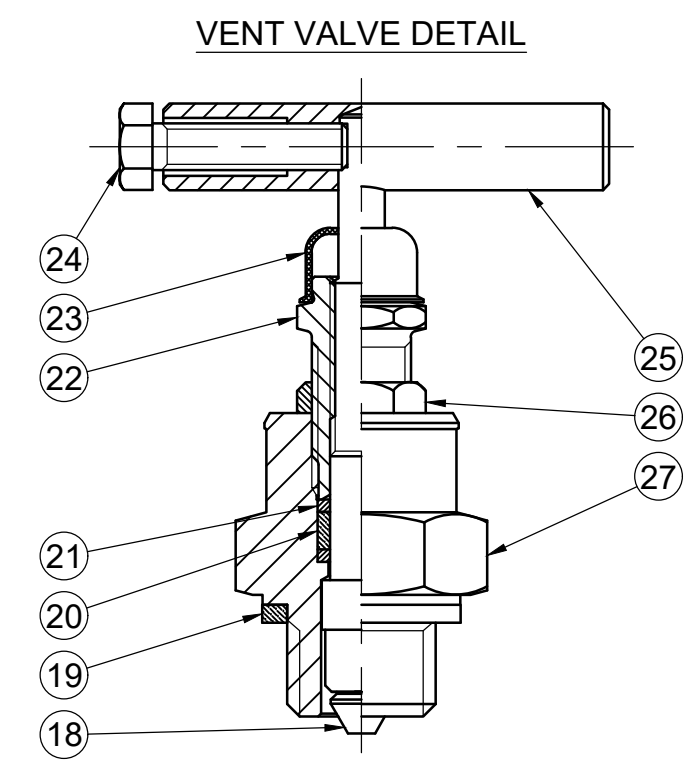
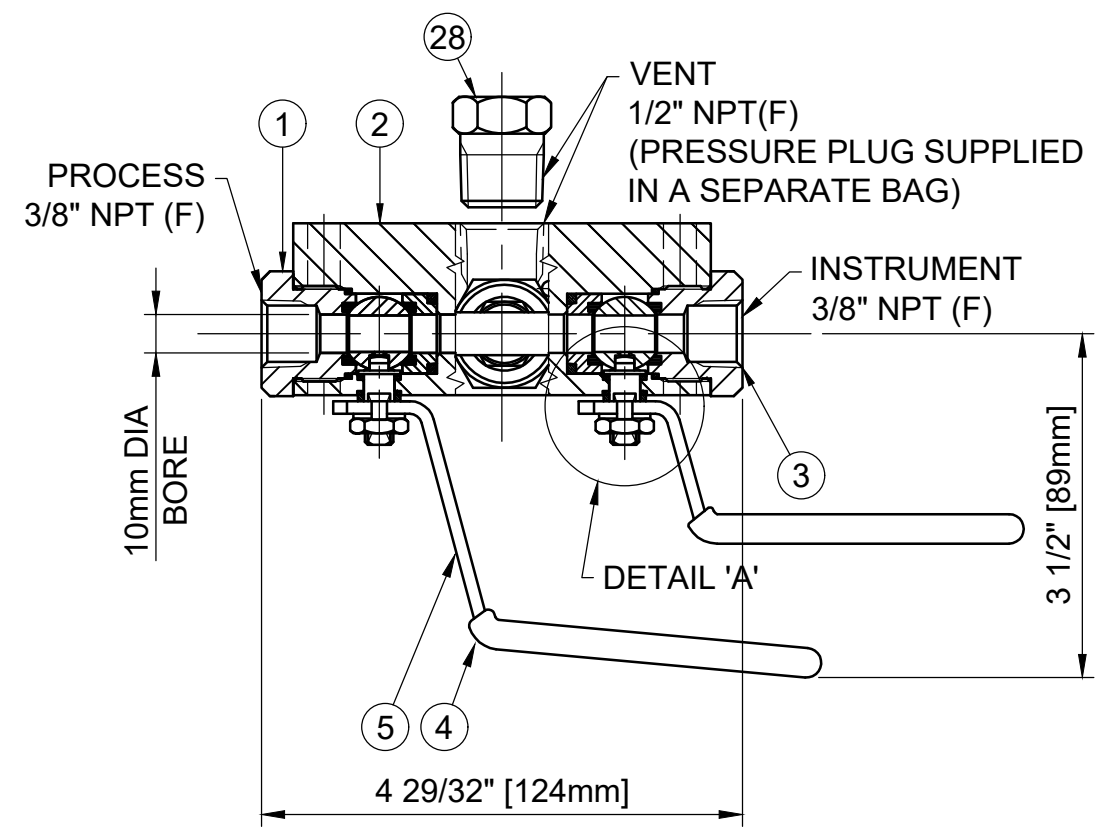
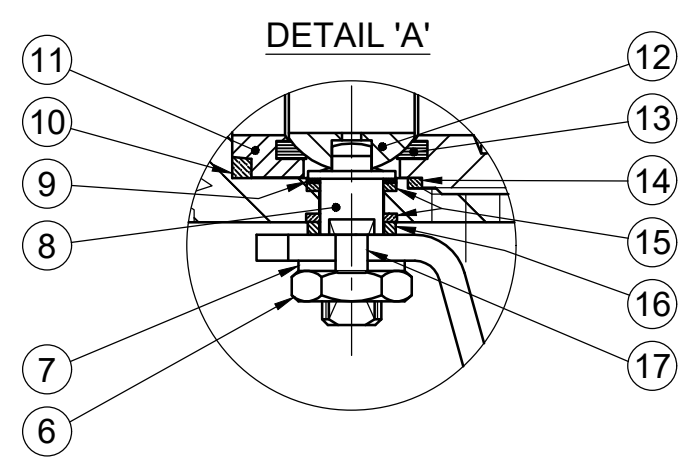

MARKING DETAILS  
 (MARKING REFERENCE ONLY)



REMARK

- ADDITIONAL TAG PLATE FOR ADDITIONAL INFO UPON REQUESTED
- HCT HEAT CODE TRACEABILITY WILL BE MARKED ON BODY & END FITTINGS

THE INFORMATION CONTAINED IN THIS DRAWING IS THE PROPERTY OF CRANE COMPANY. ANY REPRODUCTION IN PART OR AS A WHOLE WITHOUT THE WRITTEN PERMISSION OF CRANE COMPANY IS PROHIBITED.		APPROVALS CREATED JQ 16/10/2023 DRAWN JQ 16/10/2023 APPROVED ZL 18/10/2023		DATE 16/10/2023 16/10/2023 18/10/2023		CRANE   HOKE SPARTANBURG, SOUTH CAROLINA 29303	
REMOVE ALL BURRS, DO NOT SCALE DRAWING, DRILL POINTS STD		UNLESS OTHERWISE SPECIFIED, DIMENSIONS ARE IN INCHES		EC NUMBER X		TITLE GENERAL ARRANGEMENT - 10mm BORE 'ID' TYPE DOUBLE BLOCK & BLEED MANIFOLD.	
BREAK CORNERS 0.005 - 0.010		TOLERANCES ARE: .XXX +.005 ANGLES ±.01° .XX +.010 CONCENTRICITY ±0.015 .X +.060 MACHINE FINISH: 63RMS		INITIAL USAGE (REF ONLY) X		SIZE A3 SCALE N.T.S.	
CAD FILE NAME		ECN NO. XXXXX		DWG NO. A18676 SHEET 1 OF 1		REV C	