

MAXIMUM WORKING CONDITIONS
COLD WORKING PRESSURE:
 STANDARD, 6,000PSI (414BAR)
 (AT REDUCED TEMPERATURE)

TEMPERATURE:
 -29°C (-20.2°F) TO 200°C (392°F)
 (AT REDUCED PRESSURE)

NACE MR-01-75 (LATEST REVISION)
 ALL VALVES MEET NACE REQUIREMENTS

APPROX WEIGHT
 1.8 Kg

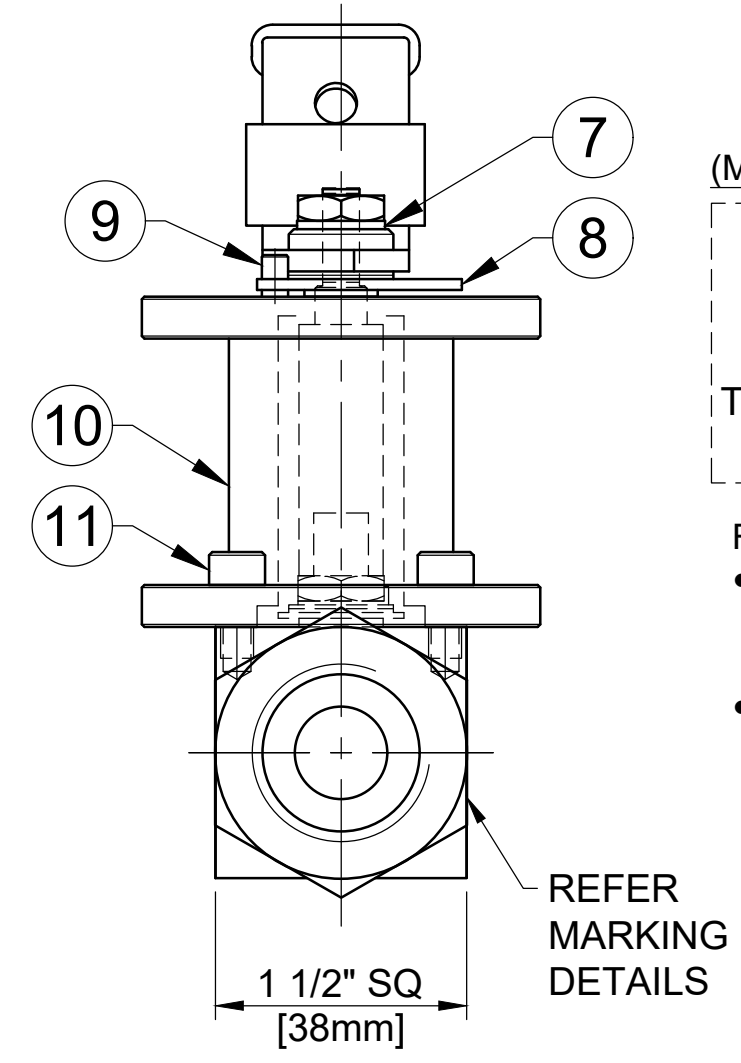
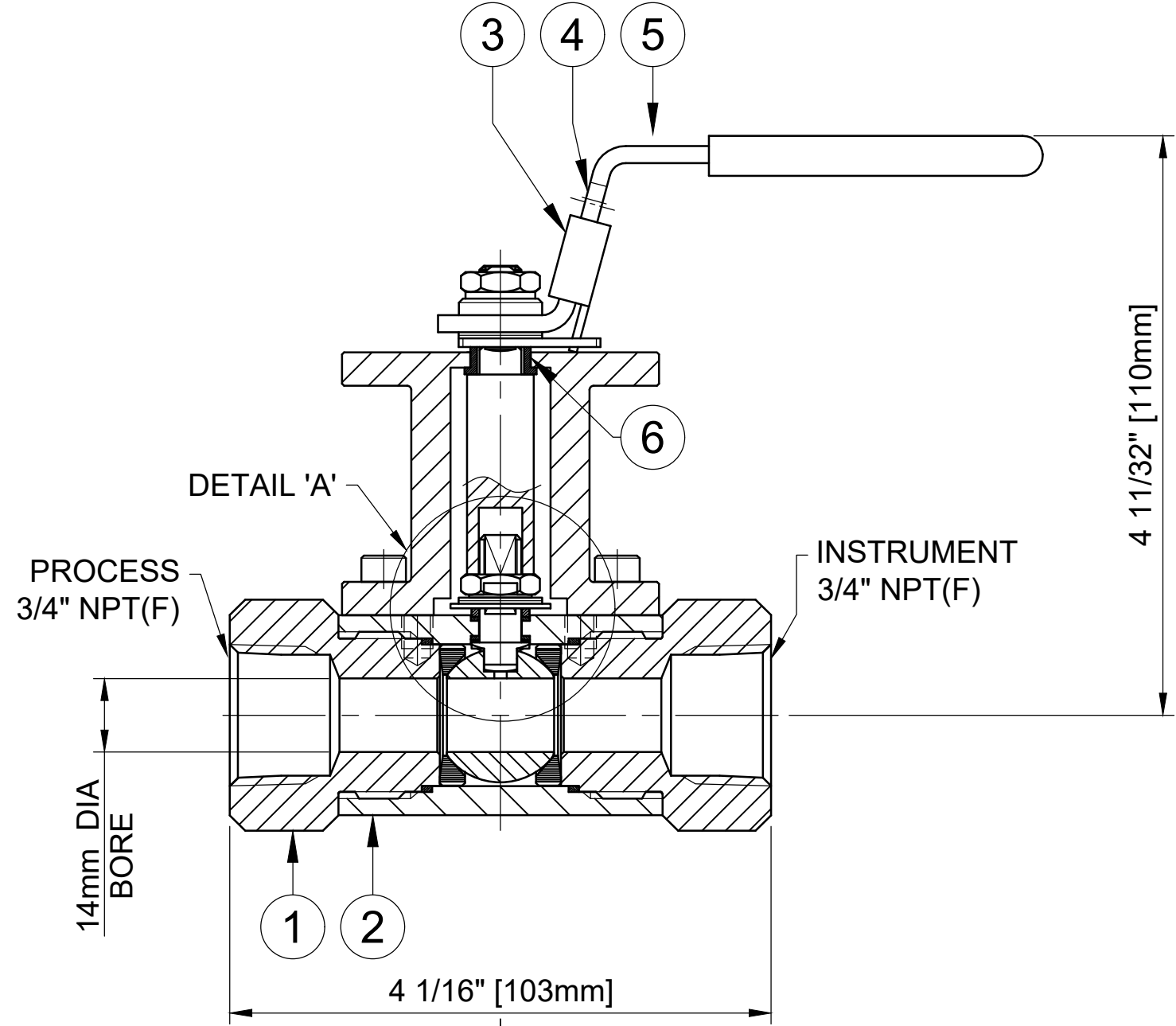

MARKING DETAILS
 (MARKING REFERENCE ONLY)



REMARK

- ADDITIONAL TAG PLATE FOR ADDITIONAL INFO UPON REQUESTED
- HCT HEAT CODE TRACEABILITY WILL BE MARKED ON BODY & END FITTINGS

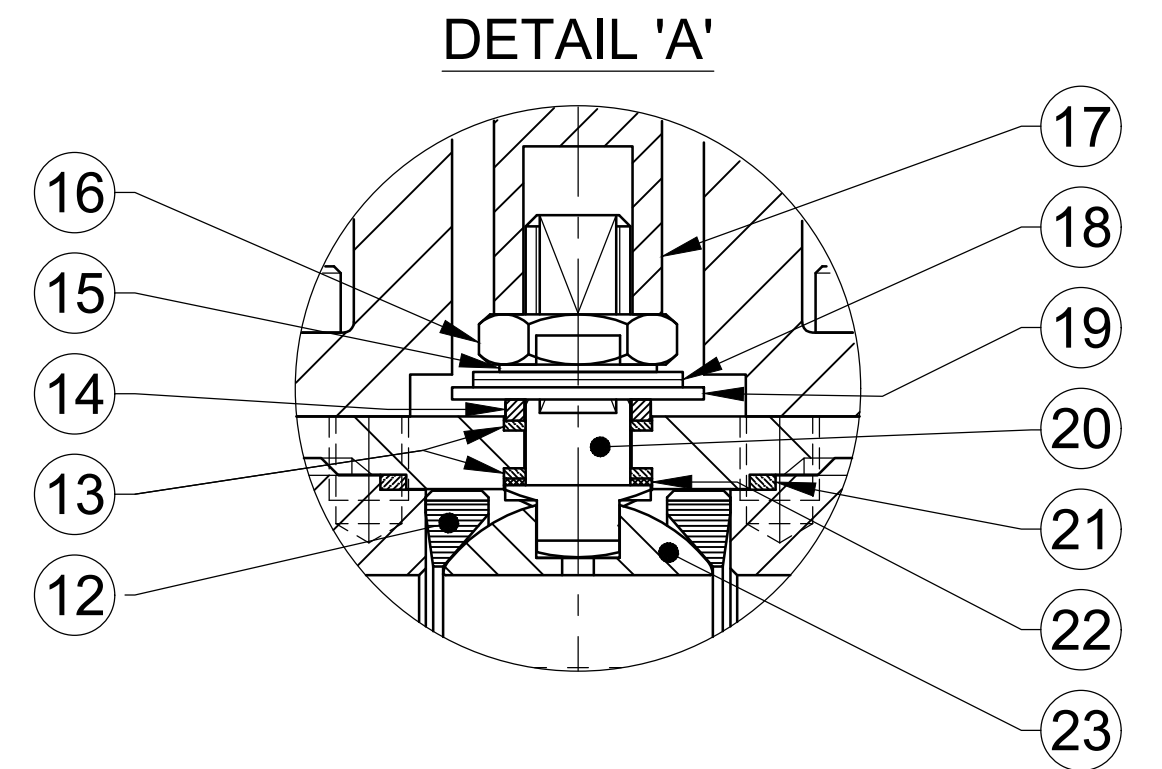
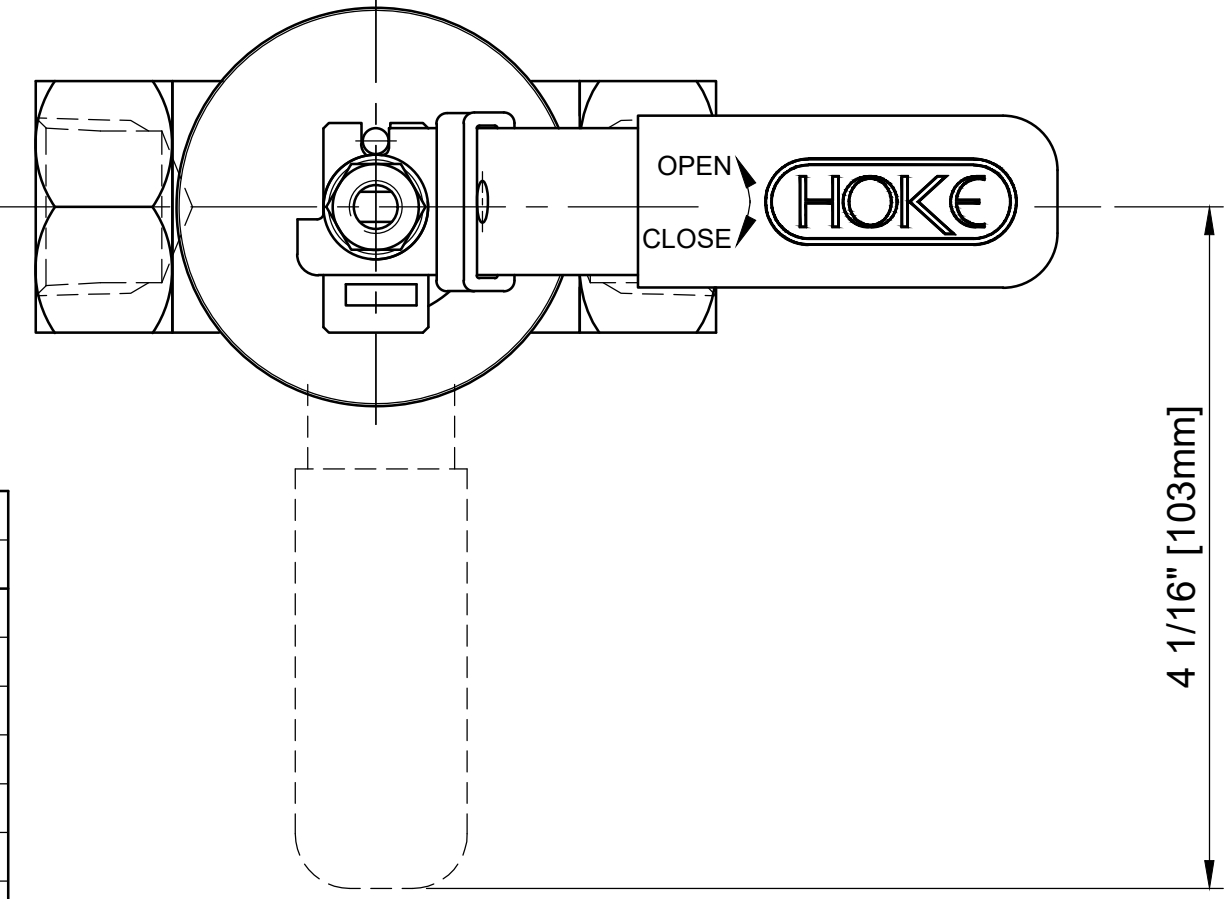

**HANDLE IS PRESSURE SENSITIVE PART
 DO NOT STEP OR CARRY BY THE HANDLE**

REF No	DESCRIPTION	MATERIAL
		6MO
1	END CONNECTOR	ASTM A276 / A479 UNS S31254
2	BODY	ASTM A276 / A479 UNS S31254
3	LOCKING TAB	316 SS
4	HANDLE	316 SS
5	SLEEVE	PVC
6	EXTENSION BUSH	TBA
7	SERRATED WASHER	316 SS
8	LOCKING PLATE	316 SS
9	HANDLE STOP PIN	316 SS
10	EXTENSION CAP	316 SS
11	CAP SCREW	316 SS
12	SEAT	PEEK
13	SPINDLE SEALS	15% GLASS FILLED PTFE
14	PISTON RING	316 SS
15	LOCK TAB	316 SS
16	NUT	A4 [316] SS
17	EXTENSION SPINDLE	ASTM B446 UNS N06625
18	DISC SRRING	316 SS
19	ANTI TORQUE PLATE	316 SS
20	SPINDLE	ASTM B446 UNS N06625
21	BODY SEAL	100% VIRGIN PTFE
22	SPINDLE SEAL	25% GLASS FILLED PTFE
23	BALL	ASTM A276 / A479 UNS S31254

THE INFORMATION CONTAINED IN THIS DRAWING IS THE PROPERTY OF CRANE COMPANY. ANY REPRODUCTION IN PART OR AS A WHOLE WITHOUT THE WRITTEN PERMISSION OF CRANE COMPANY IS PROHIBITED.	APPROVALS		DATE	SPARTANBURG, SOUTH CAROLINA 29303
	CREATED	ZL	04/01/2024	
REMOVE ALL BURRS, DO NOT SCALE DRAWING, DRILL POINTS STD	DRAWN	ZL	04/01/2024	TITLE 14mm BORE SINGLE ISOLATE BALL VALVE WITH NPT CONNECTIONS WITH EXTENDED HANDLE CAP
BREAK CORNERS 0.005 - 0.010	APPROVED	GT	05/01/2024	
TOLERANCES ARE: .XXX = ±.005 ANGLS = ±1° .XX = ±.010 CONCENTRICITY = φ 0.015 .X = ±.060 MACHINE FINISH = 63RMS	EC NUMBER	X		SIZE C PAGE CODE 28968 DWG NO. A18798 REV B SCALE N.T.S. ECHN No XXXXX SHEET 1 OF 1
		INITIAL USAGE (REF ONLY)	X	
	CAD FILE NAME			